



A+ Server®

AS -5126GS-TNRT
AS -5126GS-TNRT2

USER'S MANUAL

Revision 1.0 MNL-2767

The information in this User's Manual has been carefully reviewed and is believed to be accurate. The vendor assumes no responsibility for any inaccuracies that may be contained in this document, and makes no commitment to update or to keep current the information in this manual, or to notify any person or organization of the updates. Note: For the most up-to-date version of this manual, see our website at <https://www.supermicro.com>.

Super Micro Computer, Inc. ("Supermicro") reserves the right to make changes to the product described in this manual at any time and without notice. This product, including software and documentation, is the property of Supermicro and/or its licensors, and is supplied only under a license. Any use or reproduction of this product is not allowed, except as expressly permitted by the terms of said license.

IN NO EVENT WILL Super Micro Computer, Inc. BE LIABLE FOR DIRECT, INDIRECT, SPECIAL, INCIDENTAL, SPECULATIVE OR CONSEQUENTIAL DAMAGES ARISING FROM THE USE OR INABILITY TO USE THIS PRODUCT OR DOCUMENTATION, EVEN IF ADVISED OF THE POSSIBILITY OF SUCH DAMAGES. IN PARTICULAR, SUPER MICRO COMPUTER, INC. SHALL NOT HAVE LIABILITY FOR ANY HARDWARE, SOFTWARE, OR DATA STORED OR USED WITH THE PRODUCT, INCLUDING THE COSTS OF REPAIRING, REPLACING, INTEGRATING, INSTALLING OR RECOVERING SUCH HARDWARE, SOFTWARE, OR DATA.

Any disputes arising between manufacturer and customer shall be governed by the laws of Santa Clara County in the State of California, USA. The State of California, County of Santa Clara shall be the exclusive venue for the resolution of any such disputes. Supermicro's total liability for all claims will not exceed the price paid for the hardware product.

FCC Statement: This equipment has been tested and found to comply with the limits for a Class A or Class B digital device pursuant to Part 15 of the FCC Rules. These limits are designed to provide reasonable protection against harmful interference when the equipment is operated in industrial environment for Class A device or in residential environment for Class B device. This equipment generates, uses, and can radiate radio frequency energy and, if not installed and used in accordance with the manufacturer's instruction manual, may cause harmful interference with radio communications. Operation of this equipment in a residential area is likely to cause harmful interference, in which case you will be required to correct the interference at your own expense.

California Best Management Practices Regulations for Perchlorate Materials: This Perchlorate warning applies only to products containing CR (Manganese Dioxide) Lithium coin cells. "Perchlorate Material-special handling may apply. See <https://www.dtsc.ca.gov/hazardouswaste/perchlorate>".



WARNING: This product can expose you to chemicals including lead, known to the State of California to cause cancer and birth defects or other reproductive harm. For more information, go to <https://www.P65Warnings.ca.gov>.



AVERTISSEMENT : Ce produit peut vous exposer à des agents chimiques, y compris le plomb, identifié par l'État de Californie comme pouvant causer le cancer, des malformations congénitales ou d'autres troubles de la reproduction. Pour de plus amples informations, prière de consulter <https://www.P65Warnings.ca.gov>.

The products sold by Supermicro are not intended for and will not be used in life support systems, medical equipment, nuclear facilities or systems, aircraft, aircraft devices, aircraft/emergency communication devices or other critical systems whose failure to perform be reasonably expected to result in significant injury or loss of life or catastrophic property damage. Accordingly, Supermicro disclaims any and all liability, and should buyer use or sell such products for use in such ultra-hazardous applications, it does so entirely at its own risk. Furthermore, buyer agrees to fully indemnify, defend and hold Supermicro harmless for and against any and all claims, demands, actions, litigation, and proceedings of any kind arising out of or related to such ultra-hazardous use or sale.

Manual Revision 1.0

Release Date: June 17, 2025

Unless you request and receive written permission from Super Micro Computer, Inc., you may not copy any part of this document. Information in this document is subject to change without notice. Other products and companies referred to herein are trademarks or registered trademarks of their respective companies or mark holders.

Copyright © 2025 by Super Micro Computer, Inc.
All rights reserved.

Published in the United States of America

Preface

About This Manual

This manual is written for professional system integrators and PC technicians. It provides information for the installation and use of the AS -5126GS-TNRT/-TNRT2 server. Installation and maintenance should be performed by certified service technicians only.

Notes

For your system to work properly, follow the links below to download all necessary drivers/utilities and the user's manual for your server.

- Supermicro product manuals: <https://www.supermicro.com/support/manuals>
- Product drivers and utilities: <https://www.supermicro.com/wdl>
- Product safety info: https://www.supermicro.com/about/policies/safety_information.cfm
- A secure data deletion tool designed to fully erase all data from storage devices can be found on our website:
https://www.supermicro.com/about/policies/disclaimer.cfm?url=/wdl/utility/Lot9_Secure_Data_Deletion_Utility
- Frequently Asked Questions: <https://www.supermicro.com/FAQ/index.php>
- If you still have questions after referring to our FAQs, contact our support team. Region-specific Technical Support email addresses can be found at: "[Contacting Supermicro](#)" on page 10
- If you have any feedback on Supermicro product manuals, contact our writing team at: Techwriterteam@supermicro.com

This manual may be periodically updated without notice. Check the Supermicro website for possible updates to the manual revision level.

Conventions Used in the Manual

Special attention should be given to the following symbols for proper installation and to prevent damage done to the components or injury to yourself.



Warning! Indicates important information given to prevent equipment/property damage or personal injury.



Warning! Indicates high voltage may be encountered while performing a procedure.

Important: Important information given to ensure proper system installation or to relay safety precautions.

Note: Additional information given to differentiate various models or to provide information for proper system setup.

Contents

Contacting Supermicro	10
Chapter 1: Introduction	11
1.1 Overview	12
1.2 System Features	14
Front View	14
Drive Carrier Indicators	16
Service Tag	17
Control Panel	18
Rear View	19
1.3 System Architecture	22
Main Components	22
System Block Diagram	23
1.4 Motherboard Quick Reference	24
Motherboard Layout	24
Quick Reference Table	25
Chapter 2: Server Installation	28
2.1 Preparing for Setup	29
Choosing a Setup Location	29
Rack Precautions	29
System Precautions	29
Rack Mounting Considerations	30
Ambient Operating Temperature	31
Airflow	31
Mechanical Loading	31
Circuit Overloading	31
Reliable Ground	31
2.2 Installing the Chassis into the Rack	32
Rack Mounting Hardware	32
Mounting the Rails and Chassis to the Rack	32
Chapter 3: Maintenance and Component Installation	35
3.1 Removing Power	37

3.2 Accessing the System	38
Removing the Middle Top Cover	38
Removing the Entire Top Cover	39
3.3 Static-Sensitive Devices	40
Precautions	40
3.4 Processor and Heatsink Installation	41
Preparing the Processor Socket	41
Installing the Processor into the Frame	43
Uninstalling the Heatsink and Processor	46
3.5 Memory Support and Installation	48
Memory Support	48
General Guidelines for Optimizing Memory Performance	48
DIMM Population	48
DIMM Installation	50
DIMM Removal	52
3.6 Motherboard Battery Removal and Installation	54
Battery Removal	54
Proper Battery Disposal	54
Battery Installation	54
3.7 Storage Drives	55
Removing a Hot-Swap Drive Carrier from the Chassis	55
Installing a Drive in a Carrier	55
Hot-Swap for NVMe Drives	56
Ejecting a Drive	56
Replacing a Drive	57
3.8 System Cooling	58
Fans	58
Changing a System Fan	58
Air Shrouds	59
Installing an Air Shroud	59
3.9 Expansion Cards	61
Riser Cards	61
Installing Expansion Cards	63
AIOM Card	64

Installing AIOM	64
3.10 Power Supply	65
Replacing the Power Supply	65
Chapter 4: Motherboard Connections, Jumpers, and LEDs	67
4.1 Power Connectors	68
4.2 Headers and Connections	69
Chassis Intrusion	69
NC-SI Connection	69
TPM/Port 80 Header	69
4.3 Jumper Settings	71
CMOS Clear	71
UID LED and System_Reset Button Select Jumper	72
4.4 LED Indicators	73
BMC Heartbeat LED	73
M.2 LEDs	73
Onboard Power LED	73
Unit ID (UID) LED	74
Chapter 5: Software	75
5.1 Microsoft Windows OS Installation	76
Installing the OS	76
Driver Installation	77
5.2 BMC	79
BMC ADMIN User Password	79
Logging into the BMC	79
Chapter 6: Troubleshooting and Support	80
6.1 Online Resources	81
Direct Links for the AS -5126GS-TNRT/-TNRT2 System	81
Direct Links for General Support and Information	81
6.2 Baseboard Management Controller (BMC)	82
6.3 Troubleshooting Procedures	83
Before Power On	83
No Power	83
No Video	83
System Boot Failure	83

Memory Errors	84
Losing the System's Setup Configuration	84
If the System Becomes Unstable	84
6.4 CMOS Clear	86
6.5 Motherboard Battery	87
6.6 Where to Get Replacement Components	88
6.7 Technical Support Procedures	89
Returning Merchandise for Service	89
6.8 Feedback	91
6.9 TPM Security Module	92
Chapter 7: UEFI BIOS	93
7.1 Introduction	94
Updating BIOS	94
Starting the Setup Utility	94
7.2 Main Setup	96
7.3 Advanced Setup Configurations	98
Boot Feature Menu	98
CPU Configuration Menu	100
NB Configuration	102
Trusted Computing Menu	105
ACPI Settings Menu	105
Super IO Configuration Menu	106
Serial Port 1 Configuration Menu	106
Serial Port 2 Configuration Menu	106
Serial Port Console Redirection Menu	107
PCIe/PCI/PnP Configuration Menu	109
USB Configuration	110
Network Configuration Menu	111
SATA Configuration Menu	113
HTTP Boot Configuration Menu	114
Supermicro KMS Server Configuration Menu	114
Super-Guardians Configuration Menu	116
TLS Authenticate Configuration Menu	118
Driver Health Menu	119

7.4 Event Logs	120
7.5 BMC	122
System Event Log Menu	122
BMC Network Configuration Menu	123
7.6 Security	126
7.7 Boot	128
7.8 Save & Exit	130
Appendix A: BIOS Codes	132
BIOS Error POST (Beep) Codes	132
Additional BIOS POST Codes	132
Appendix B: Standardized Warning Statements for AC Systems	133
Warning Definition	133
Installation Instructions	135
Circuit Breaker	136
Power Disconnection Warning	138
Equipment Installation	139
Restricted Area	141
Battery Handling	142
Redundant Power Supplies	144
Backplane Voltage	145
Comply with Local and National Electrical Codes	147
Product Disposal	148
Fan Warning	149
Power Cable and AC Adapter	151
Appendix C: System Specifications	155

Contacting Supermicro

Headquarters

Address: Super Micro Computer, Inc.
980 Rock Ave.
San Jose, CA 95131 U.S.A.

Tel: +1 (408) 503-8000

Fax: +1 (408) 503-8008

Email: Marketing@supermicro.com (General Information)
Sales-USA@supermicro.com (Sales Inquiries)
[Government Sales-USA@supermicro.com](mailto:Government_Sales-USA@supermicro.com) (Gov. Sales Inquiries)
Support@supermicro.com (Technical Support)
RMA@Supermicro.com (RMA Support)
Webmaster@supermicro.com (Webmaster)

Website: <https://www.supermicro.com>

Europe

Address: Super Micro Computer B.V.
Het Sterrenbeeld 28, 5215 ML
's-Hertogenbosch, The Netherlands

Tel: +31 (0) 73-6400390

Fax: +31 (0) 73-6416525

Email: Sales_Europe@supermicro.com (Sales Inquiries)
Support_Europe@supermicro.com (Technical Support)
RMA_Europe@supermicro.com (RMA Support)

Website: <https://www.supermicro.nl>

Asia-Pacific

Address: Super Micro Computer, Inc.
3F, No. 150, Jian 1st Rd.
Zhonghe Dist., New Taipei City 235 Taiwan (R.O.C)

Tel: +886 (2) 8226-3990

Fax: +886 (2) 8226-3992

Email: Sales-Asia@supermicro.com.tw (Sales Inquiries)
Support@supermicro.com.tw (Technical Support)
RMA@supermicro.com.tw (RMA Support)

Website: <https://www.supermicro.com.tw>

Chapter 1:

Introduction

This chapter provides a brief outline of the functions and features of the AS -5126GS-TNRT/-TNRT2 system. It is based on the H14DSG-O-CPU motherboard and the CSE-528G2TS-R000NDP chassis.

1.1 Overview	12
1.2 System Features	14
Front View	14
Rear View	19
1.3 System Architecture	22
Main Components	22
System Block Diagram	23
1.4 Motherboard Quick Reference	24
Motherboard Layout	24
Quick Reference Table	25

1.1 Overview

The A+ Server® AS -5126GS-TNRT/-TNRT2 is an H14 system that supports dual AMD EPYC™ 9005/9004 Series Processors in a 5U form factor. The system is based on the H14DSG-O-CPU motherboard and the CSE-528G2TS-R000NDP chassis.

The following provides an overview of the specifications and capabilities of the A+ Server® AS -5126GS-TNRT/-TNRT2.

System Overview	
Motherboard	H14DSG-O-CPU
Chassis	CSE-528G2TS-R000NDP
Processor	Dual AMD EPYC™ 9005/9004 Series Processors in Socket SP5 and a Thermal Design Power up to 500 W
Memory	24 DIMM slots with 1DPC that support up to: 6 TB registered ECC DDR5 4800 MT/s speed with AMD EPYCTM 9004 Series processors installed 6 TB registered ECC DDR5 6400 MT/s speed with AMD EPYCTM 9005 Series processors installed
Drive Support	AS -5126GS-TNRT: Total six drive bays Two front hot-swap 2.5" SATA drive bays Up to four front hot-swap 2.5" NVMe drive bays AS -5126GS-TNRT2: Total 10 drive bays Two front hot-swap 2.5" SATA drive bays Eight front hot-swap 2.5" NVMe drive bays
Expansion Slots	AS -5126GS-TNRT: Up to 10 PCIe 5.0 x16 slots (full-height, full-length) depending on configuration AS -5126GS-TNRT2: Up to 13 PCIe 5.0 x16 slots (full-height, full-Length) + one AIOM/OCP slot
I/O Ports	One RJ45 1 GbE dedicated BMC LAN port Two RJ45 10 GbE BASE-T LAN ports Two USB 3.2 Gen 1 ports One VGA port
System Cooling	10 heavy-duty fans with optimal fan speed control
Power	Six 2700 W redundant (3+3) Titanium Level (96%) power supplies. Full redundancy based on configuration and application load.
Form Factor	5U: 17.2 x 8.75 x 29 in. / 437 x 222.5 x 737 mm (WxHxD)

Note: A Quick Reference Guide can be found on the product page of the Supermicro Website. The following safety models associated with the AS -5126GS-TNRT/-TNRT2 have been certified as compliant with UL or CSA: 528G-H27H14, 528G-27.

1.2 System Features

The following views of the system display the main features. Refer to the System Specifications appendix of this manual for additional specifications.

Front View

The following features are located on the front of the AS -5126GS-TNRT/-TNRT2. The logical storage drives for each server varies depending on the different configurations.

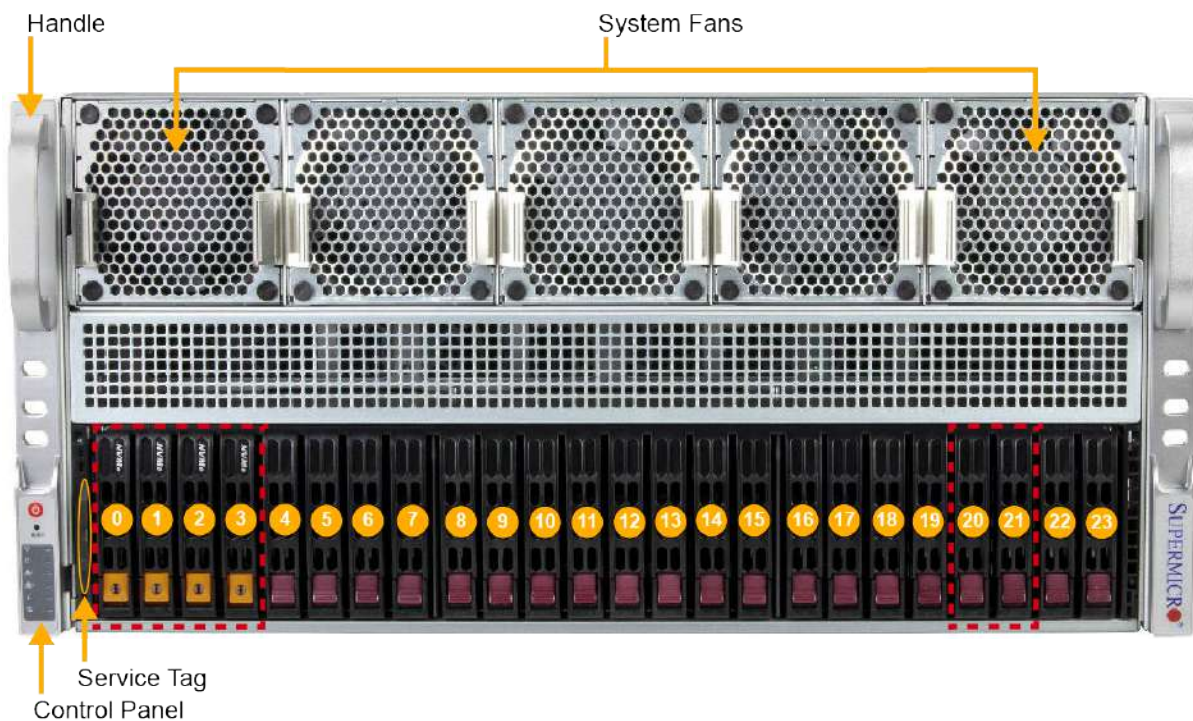

Figure 1-1. AS -5126GS-TNRT Front View

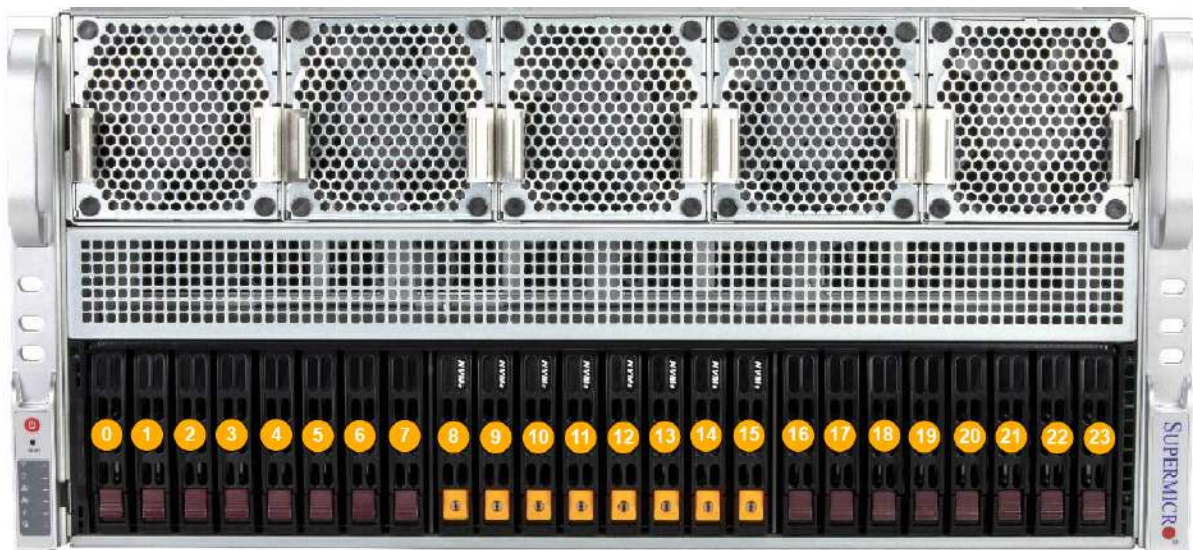

Figure 1-2. AS -5126GS-TNRT2 Front View

System Features: Front	
Feature	Description
Handle	One hand grip on each side (left and right) of the chassis for handling during servicing.
Control Panel	Front control panel with LEDs and buttons. See the Control Panel for more details.
Service Tag	Pull-out service or asset tag has the BMC password details, as noted in the table below.
System Fans	Five front heavy-duty fans with optimal fan speed control.

Logical Storage Drive Numbers		
System SKU	Item	Description
AS -5126GS-TNRT	0-3	Four hot-swap 2.5" NVMe drive bays
	20-21	Two hot-swap 2.5" SATA drive bays
AS -5126GS-TNRT2	8-15	Eight hot-swap 2.5" NVMe drive bays
	20-21	Two hot-swap 2.5" SATA drive bays
For AS -5126GS-TNRT2, 0-7 is applied only to the 24x NVMe drive configuration.		

Drive Carrier Indicators

Each drive carrier has two LED indicators: an activity indicator and a status indicator. For RAID configurations using a controller, the meaning of the status indicator is described in the table below.

Drive Carrier LED Indicators			
LED	Color	Pattern	Device Behavior
Activity LED	Blue	Solid	Idle SAS/NVMe drive installed
	Blue	Blinking	I/O activity
	Off	N/A	Idle SATA drive installed
Status LED	Red	Solid	Failure of drive with RAID support
	Red	Blinking at 1 Hz	Rebuild drive with RAID support
	Red	Blinking with two blinks and one stop at 1 Hz	Hot spare for drive with RAID support
	Red	On for five seconds, then off	Power on for drive with RAID support
	Red	Blinking at 4 Hz	Identify drive with RAID support

Service Tag

The server features a service tag, which is used to identify the system and to track any maintenance, upgrades, changes to the system. It is located on the front of the chassis, towards the left side.

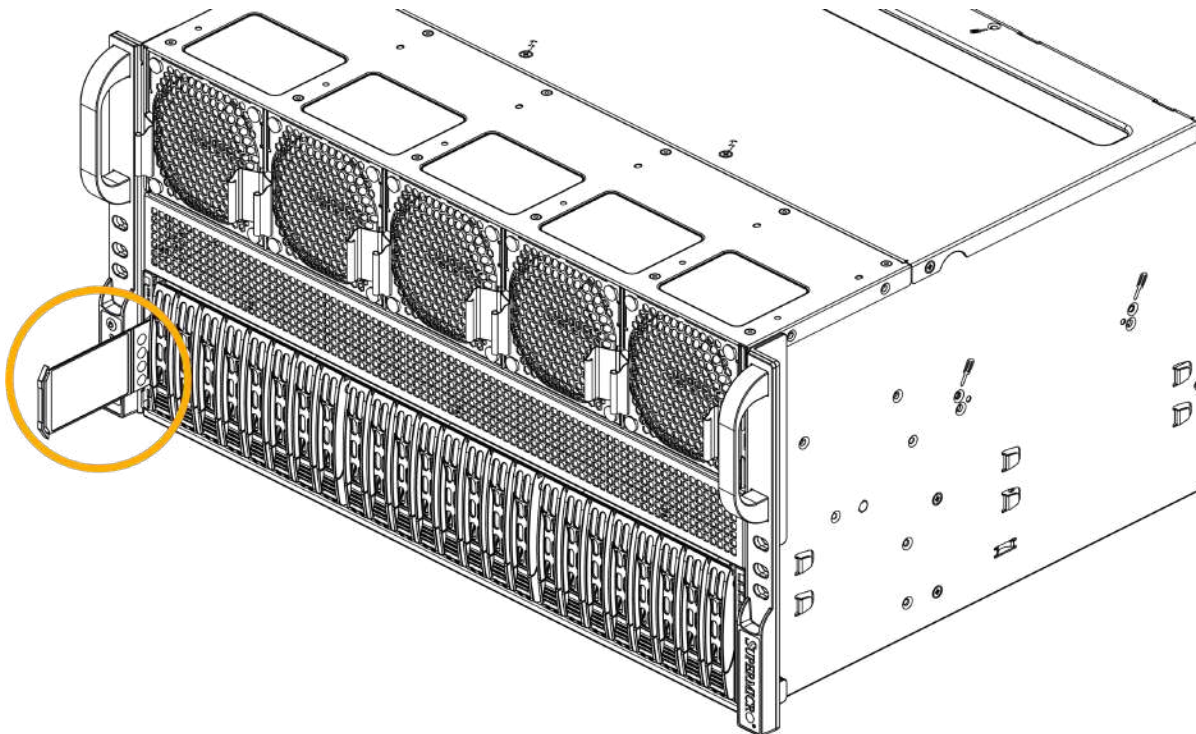

Figure 1-3. Service Tag Location

Control Panel

The following switches and LEDs are located on the AS -5126GS-TNRT and AS -5126GS-TNRT2 control panel.

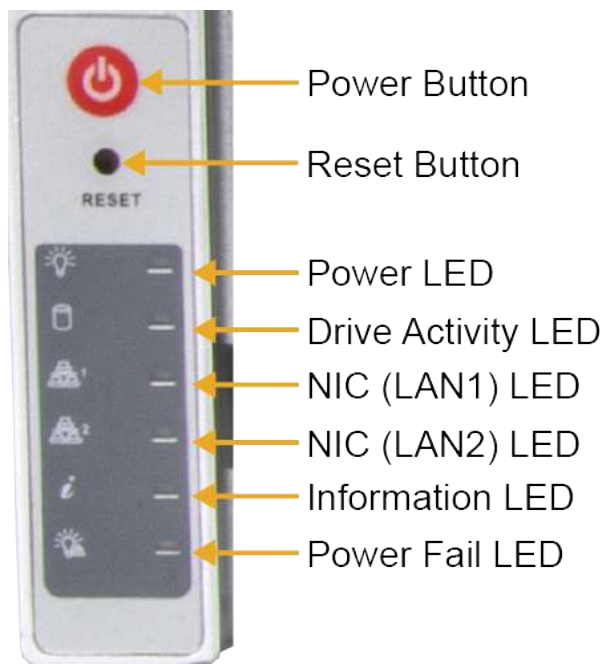

Figure 1-4. Control Panel

Control Panel Features	
Feature	Description
Power Button	The main power button is used to apply or remove power from the power supply to the server. Turning off system power with this button removes the main power but maintains standby power. To perform many maintenance tasks, you must also unplug system before servicing.
Reset Button	This button can also be used to reset the BMC.
Power LED	Indicates power is being supplied to the system power supply. This LED should normally be illuminated when the system is operating.
Drive Activity LED	Indicates activity on a storage drive when flashing.
NIC (LAN1) LED	Indicates network activity on LAN1 when flashing.
NIC (LAN2) LED	Indicates network activity on LAN2 when flashing.
Information LED	Alerts operator to several states, as noted in the table below.
Power Fail LED	Indicates a power supply module has failed.

Information LED	
Color, Status	Description
Red, solid	An overheat condition has occurred.
Red, blinking at 1 Hz	Fan failure; check for an inoperative fan.
Red, blinking at 0.25 Hz	Power failure; check for an inoperative power supply.
Red, solid with Power LED blinking green	Fault detected.
Blue and red, blinking at 10 Hz	Recovery mode.
Blue, solid	UID has been activated locally to locate the server in a rack environment.
Blue, blinking at 1 Hz	UID has been activated via BMC to locate the server in a rack environment.
Blue, blinking at 2 Hz	BMC is resetting.
Blue, blinking at 4 Hz	BMC is setting factory defaults.
Blue, blinking at 10 Hz with Power LED blinking green	BMC/BIOS firmware is updating.

Rear View

The following features are located on the rear of the AS -5126GS-TNRT/-TNRT2. The expansion slot locations for each server varies depending on the different configurations.

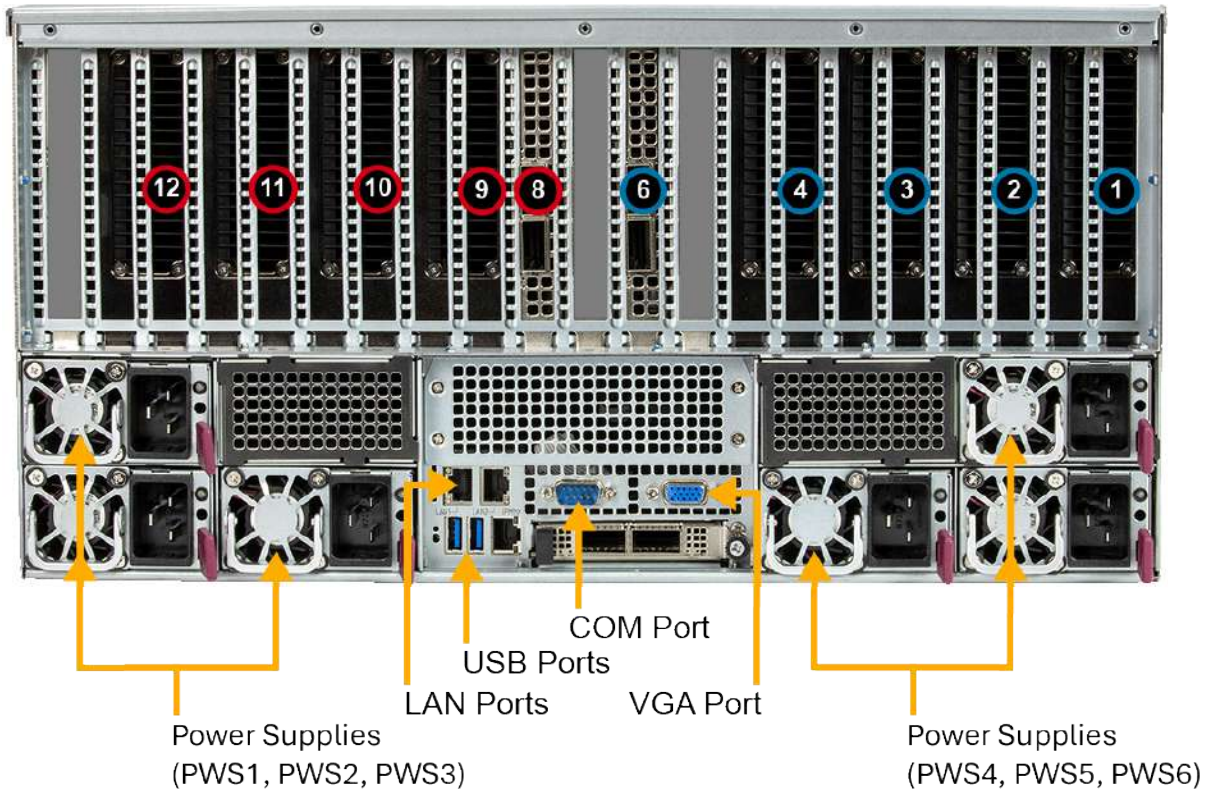

Figure 1-5. AS -5126GS-TNRT Rear View

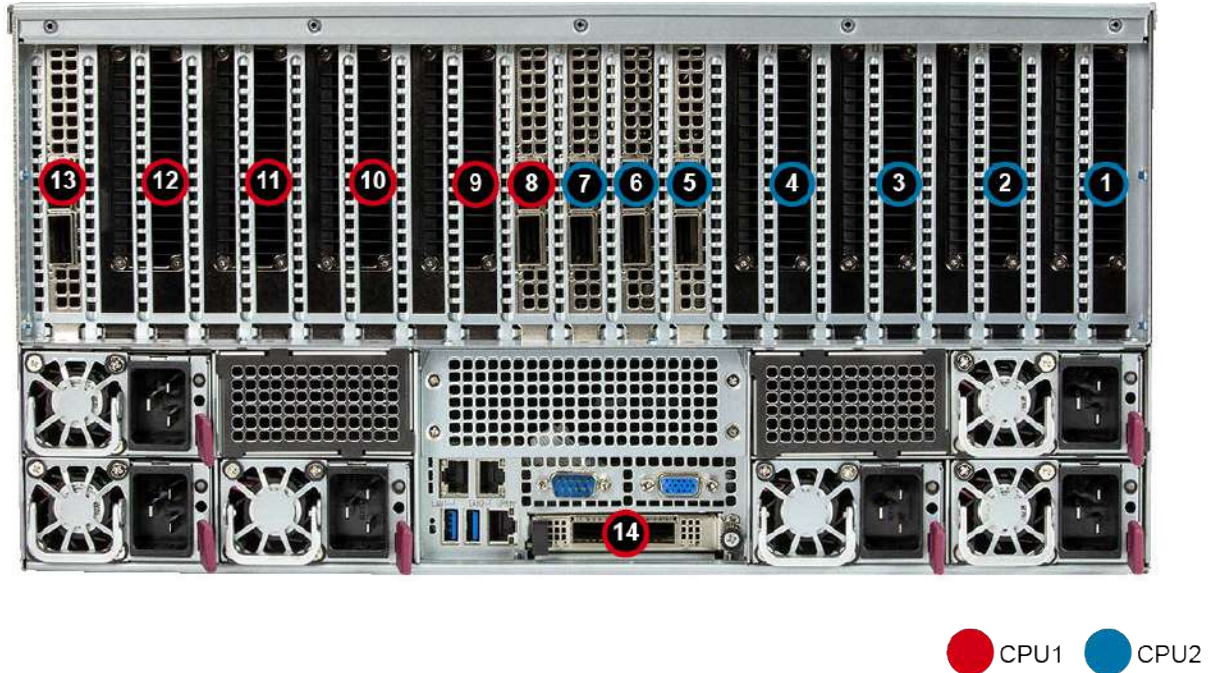

Figure 1-6. AS -5126GS-TNRT2 Rear View

System Features: Rear	
Feature	Description
Power Supplies	Six hot-swap redundant 2700 W Titanium Level power supply modules (3+3 redundancy) PWS1 and PWS6 are at the top, PWS2 and PWS3 are at the bottom left, and PWS5 and PWS6 are at the bottom right.
LAN Ports	Two RJ45 LAN ports One dedicated IPMI port
USB Ports	Two Type-A USB 3.0 ports
COM Port	One serial port for high speed serial communication
VGA Port	One legacy VGA interface for video
<p>For both servers, the power supply modules are fully redundant based on the configuration and application load.</p> <p>There's also the option for two additional power supplies for a total of eight power supply modules.</p>	

Expansion Slot Locations		
System SKU	Item	Description
AS -5126GS-TNRT	1-4, 6, 9-12	PCIe 5.0 x16 (full-height, full-length)
	8	PCIe 5.0 x16 or x8 (full-height, full-length)
AS -5126GS-TNRT2	1-13	PCIe 5.0 x16 (full-height, full-length)
	14	PCIe 5.0 x16 AIOM (OCP 3.0)
<p>In AS -5126GS-TNRT, slot 8 supports PCIe lanes based on the NVMe drive bay configuration.</p>		

1.3 System Architecture

This section covers the locations of the system's main components and provides a motherboard block diagram.

Main Components

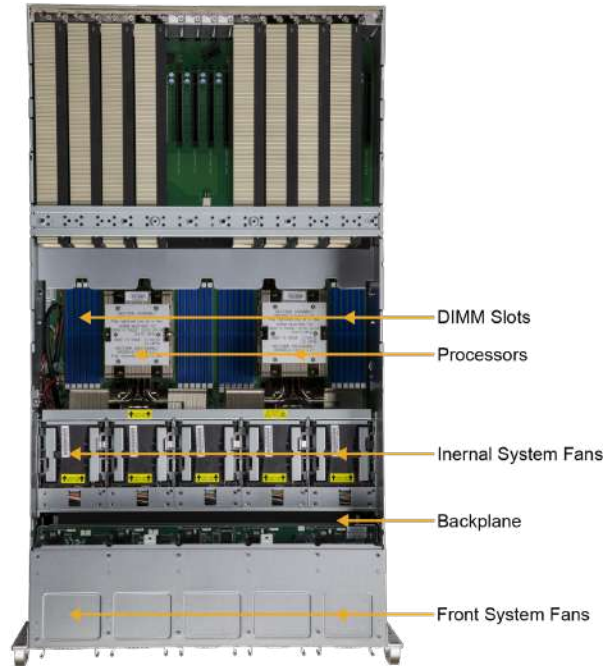

Figure 1-7. AS -5126GS-TNRT/-TNRT2 Main Component Locations

System Features: Top	
Feature	Description
DIMM Slots	24 DDR5 DIMM slots
Processors	Dual AMD EPYC™ 9005/9004 series processors
System Fans	Five internal system fans Five external (front) system fans
Backplane	NVMe Gen5 24-slot direct-attached backplane (BPN-NVME5-HS219N-S24)

System Block Diagram

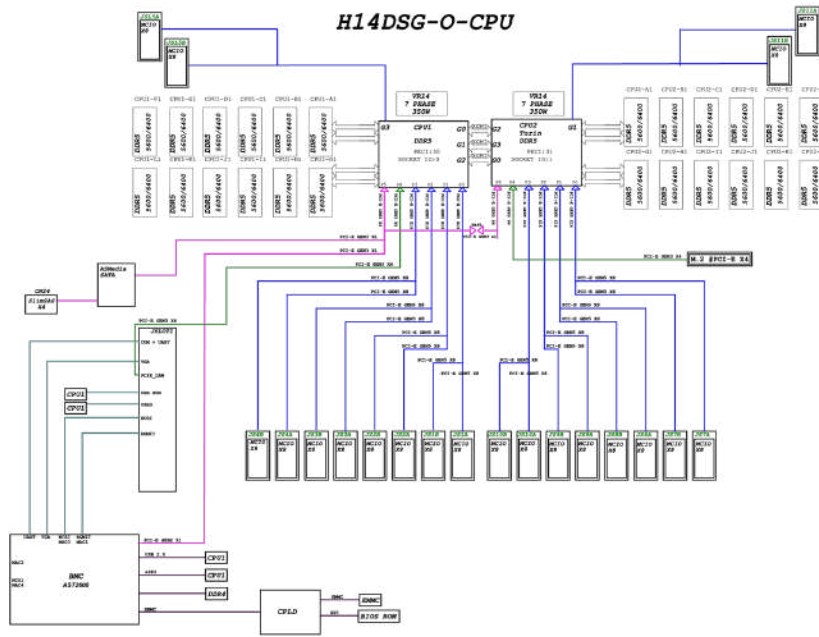

Figure 1-8. System Block Diagram

1.4 Motherboard Quick Reference

For details on the H14DSG-O-CPU motherboard layout and other quick reference information, refer to the content below.

Motherboard Layout

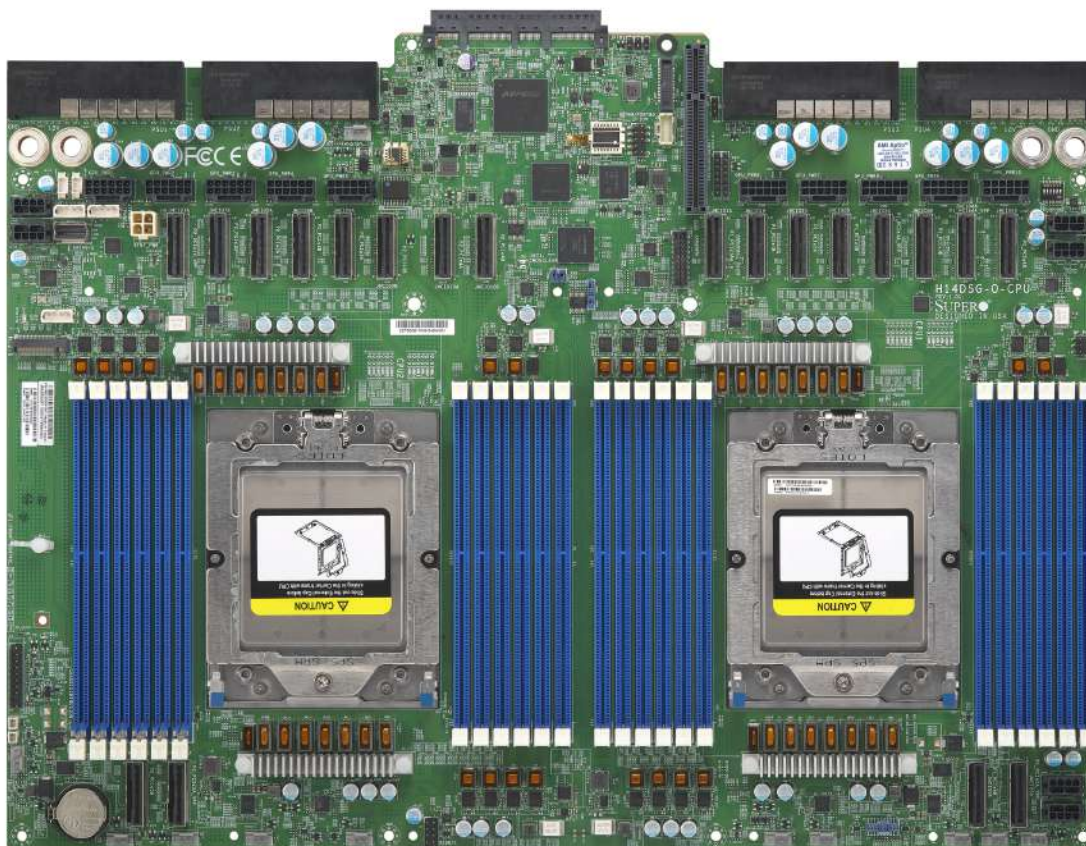

Figure 1-9. H14DSG-O-CPU Motherboard Image

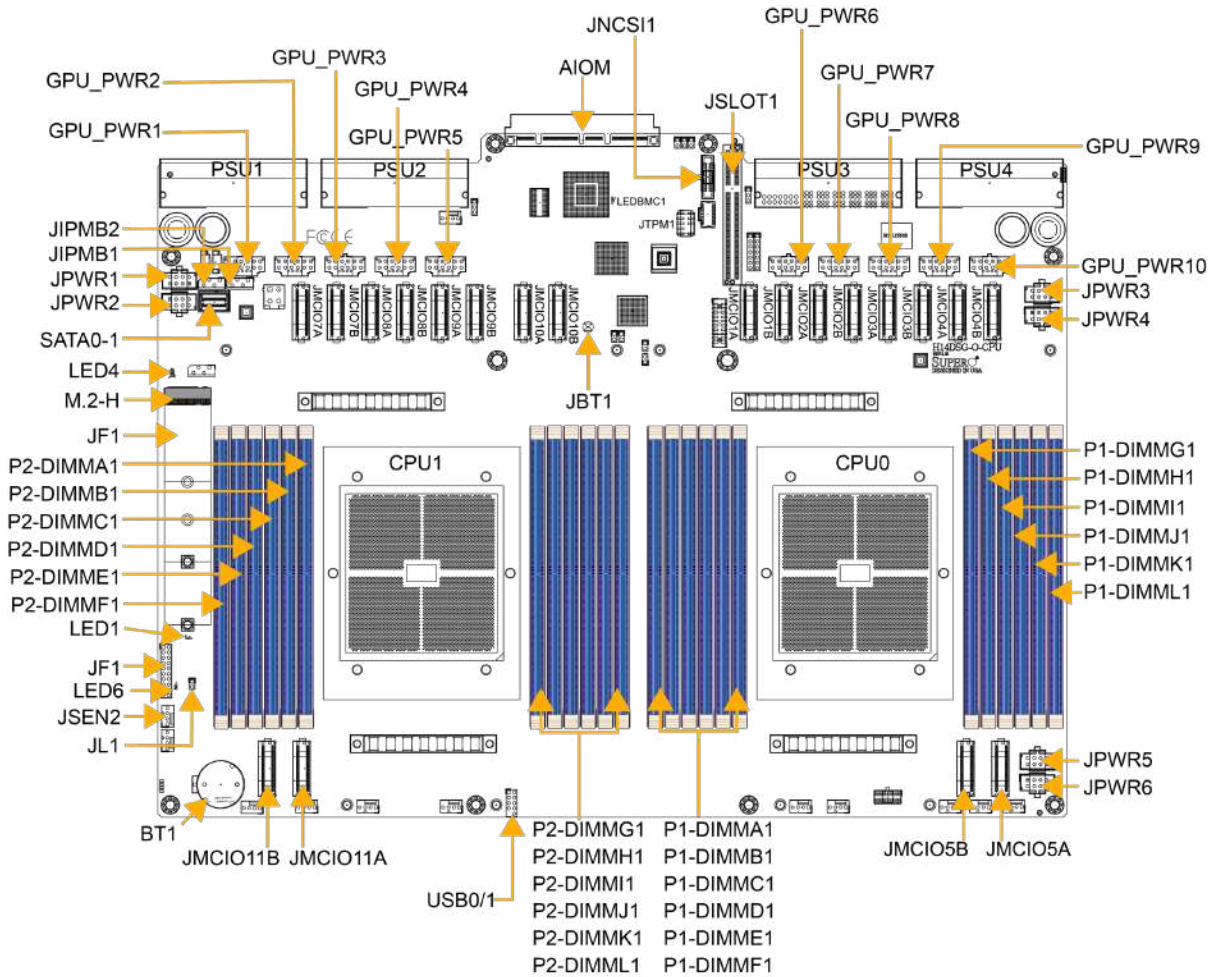

Figure 1-10. H14DSG-O-CPU Motherboard Layout

Notes:

- For detailed information on jumpers, connectors, and LED indicators, see ["Maintenance and Component Installation"](#) on page 35.
- "■" indicates the location of pin 1.
- Components not documented are for internal testing purposes only.
- Use only the correct type of onboard CMOS battery as specified by the manufacturer. To avoid possible explosion, do not install the onboard battery upside down.

Quick Reference Table

Jumper	Description	Default Setting
JBT1	CMOS Clear	Open (Normal)

LED	Description	Status
LED1	UID LED	Solid Blue: Unit Identified
LED4	M.2 LED	Green: On
LED6	Power LED	Solid Green: Power On
LEDBMC1	BMC Heartbeat LED	Blinking Green: BMC Normal Green: Fast blinking (BMC Initializing)

Connector	Description
AIOM	Supermicro Advanced I/O Module (AOM-528G2-AIOM)
BT1	Onboard Battery
GPU_PWR1- GPU_PWR10	Power connectors 1 to 10 for supplying power to the GPU.
JF1	Front Control Panel Header
JL1	Chassis Intrusion Header
JMCIO1A JMCIO1B JMCIO2A JMCIO2B JMCIO3A JMCIO3B JMCIO4A JMCIO4B JMCIO5A JMCIO5B	Processor 1 PCIe 5.0 x8
JMCIO7A JMCIO7B JMCIO8A JMCIO8B JMCIO9A JMCIO9B JMCIO10A JMCIO10B JMCIO11A JMCIO11B	Processor 2 PCIe 5.0 x8

Connector	Description
JNCSI1	Network Controller Sideband Interface (NC-SI) Connector
JPWR1- JPWR6	8-pin Power Connectors
JSEN2	Sensor connector for interfacing with environmental or hardware sensors, allowing for data collection and monitoring.
JSLOT1	Supermicro I/O Riser Slot (AOM-PTG-I2T)
JTPM1	Trusted Platform Module/Port 80 Connector
M.2-H	M.2 PCIe 5.0 x2 Slots in 25110/22110/2280 Form Factor
PSU1-PSU4	Power Supply Units 1 to 4 for System Power Usage
USB0/1	Front Accessible USB 2.0 Gen 1 Header

Note: Jumpers, connectors, switches, and LED indicators that are not described in these tables are for manufacturing testing purposes only, and are not covered in this manual.

Chapter 2:

Server Installation

This chapter provides advice and instructions for mounting your server in a server rack. If your server is not already fully integrated with processors, system memory, etc., refer to ["Maintenance and Component Installation" on page 35](#) for details on installing those specific components.

Important: Electrostatic Discharge (ESD) can damage electronic components. To prevent such damage to printed circuit boards (PCBs), it is important to use a grounded wrist strap, handle all PCBs by their edges, and keep PCBs in anti-static bags when not in use.

2.1 Preparing for Setup	29
Choosing a Setup Location	29
Rack Precautions	29
System Precautions	29
Rack Mounting Considerations	30
2.2 Installing the Chassis into the Rack	32
Rack Mounting Hardware	32
Mounting the Rails and Chassis to the Rack	32

2.1 Preparing for Setup

The box in which the AS -5126GS-TNRT/-TNRT2 server was shipped should include the rackmount hardware needed to install it into the rack. Read this section in its entirety before you begin the installation.

Choosing a Setup Location

- The server should be situated in a clean, dust-free area that is well ventilated. Avoid areas where heat, electrical noise and electromagnetic fields are generated.
- Leave enough clearance in front of the rack so that you can open the front door completely (~25 inches) and approximately 30 inches of clearance in the back of the rack to allow sufficient space for airflow and access when servicing.
- This product should be installed only in a Restricted Access Location (dedicated equipment rooms, service closets, etc.).
- This product is not suitable for use with visual display workplace devices according to §2 of the German Ordinance for Work with Visual Display Units.

Rack Precautions

- Ensure that the leveling jacks on the bottom of the rack are extended to the floor so that the full weight of the rack rests on them.
- In single rack installations, stabilizers should be attached to the rack. In multiple rack installations, the racks should be coupled together.
- Always make sure the rack is stable before extending a server or other component from the rack.
- You should extend only one server or component at a time. Extending two or more simultaneously may cause the rack to become unstable.

System Precautions

- Review the electrical and general safety precautions in "[Standardized Warning Statements for AC Systems](#)" on page 133.
- Determine the placement of each component in the rack before you install the rails.
- Install the heaviest server components at the bottom of the rack first and then work your way up.

- Use a regulating uninterruptible power supply (UPS) to protect the server from power surges and voltage spikes and to keep your system operating in case of a power failure.
- Allow any drives and power supply modules to cool before touching them.
- When not servicing, always keep the front door of the rack and all covers/panels on the servers closed to maintain proper cooling.

Rack Mounting Considerations



Warning! Stability hazard. The rack may tip over causing serious personal injury. Before extending the rack to the installation position, read the installation instructions. Do not put any load on the slide-rail mounted equipment in the installation position. Do not leave the slide-rail mounted equipment in the installation position.



Avertissement!

Danger d'instabilité. Le rack peut basculer et provoquer des blessures corporelles graves.

Avant d'étendre le rack en position d'installation, lire les instructions d'installation. Ne pas charger l'équipement monté sur rail de glissière en position d'installation. Ne pas laisser l'équipement monté sur rail de glissière en position d'installation.

Important: To prevent bodily injury when mounting or servicing this unit in a rack, you must take special precautions to ensure that the system remains stable. The following guidelines are provided to ensure your safety:

- If this unit is the only unit in the rack, it should be mounted at the bottom of the rack.
- When mounting this unit in a partially filled rack, load the rack from the bottom to the top, placing the heaviest component at the bottom of the rack.
- If the rack is provided with stabilizing devices, install the stabilizers before mounting or servicing the unit in the rack.
- Slide rail mounted equipment is not to be used as a shelf or a workspace.
- Do not pick up the server with the front handles. They are designed to pull the system from a rack only.

Ambient Operating Temperature

If installed in a closed or multi-unit rack assembly, the ambient operating temperature of the rack environment may be greater than the room's ambient temperature. Therefore, consideration should be given to installing the equipment in an environment compatible with the manufacturer's maximum rated ambient temperature (TMRA).

Airflow

Equipment should be mounted into a rack so that the amount of airflow required for safe operation is not compromised.

Mechanical Loading

Equipment should be mounted into a rack so that a hazardous condition does not arise due to uneven mechanical loading.

Circuit Overloading

Consideration should be given to the connection of the equipment to the power supply circuitry and the effect that any possible overloading of circuits might have on overcurrent protection and power supply wiring. Appropriate consideration of equipment nameplate ratings should be used when addressing this concern.

Reliable Ground

A reliable ground must be maintained at all times. To ensure this, the rack itself should be grounded. Particular attention should be given to power supply connections other than the direct connections to the branch circuit (i.e. the use of power strips, etc.).

2.2 Installing the Chassis into the Rack

This section provides information on installing the chassis into a rack. There are a variety of rack units on the market, meaning the procedure may differ slightly.

Rack Mounting Hardware

The following is a list of rack mounting hardware you will need for rack setup and installation with the AS -5126GS-TNRT/-TNRT2 server.

- Two rail assemblies (one for each side of the chassis)
- Two handles
- Four roundhead screws for fastening the enclosure ears to the rack
- Eight flathead screws and washers for mounting the rails to the rack

Mounting the Rails and Chassis to the Rack

Important: Use caution when mounting or removing the system from the rack. For large systems, at least one other person must assist during installation or removal. Follow the safety recommendations printed on the rails. Depending on the size of the system, you might need to use a lift.

1. Decide where you want to place the chassis into the rack; for details, see "[Preparing for Setup](#)" on page 29.
2. Position the Enclosure Template at the front of the chassis to determine the locations of the screws for the chassis rails.

Important: This figure is for illustrative purposes only. Always install servers to the bottom of a rack first.

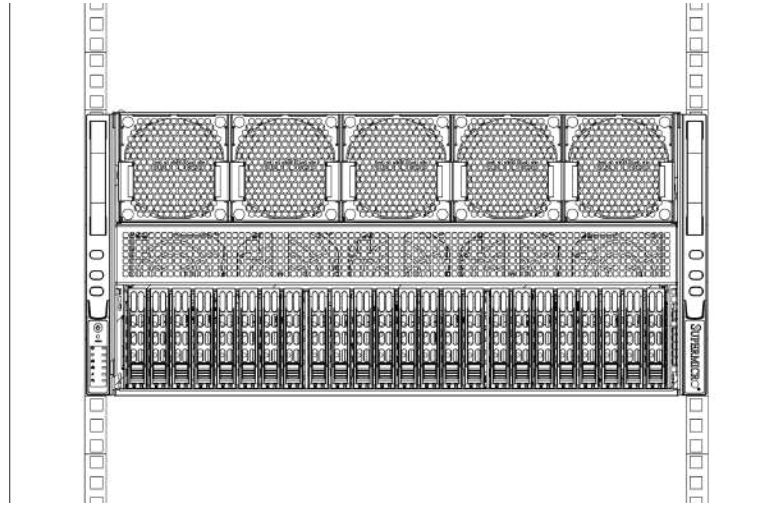

Figure 2-1. Positioning the Enclosure Template

3. The two rail sections are screwed together to keep them immobile during shipping. Release these screws just enough to allow the rails to slide apart. Note the arrow on the rail, which indicates the end that attaches to the front of the rack.
4. Slide the rails apart far enough to match the depth of the rack. Position the rails with the template and secure the front of each to the front of the rack with two flathead screws, then secure the back of each rail to the rear of the rack with two flathead screws. Note that the rails are left/right-specific and very heavy.

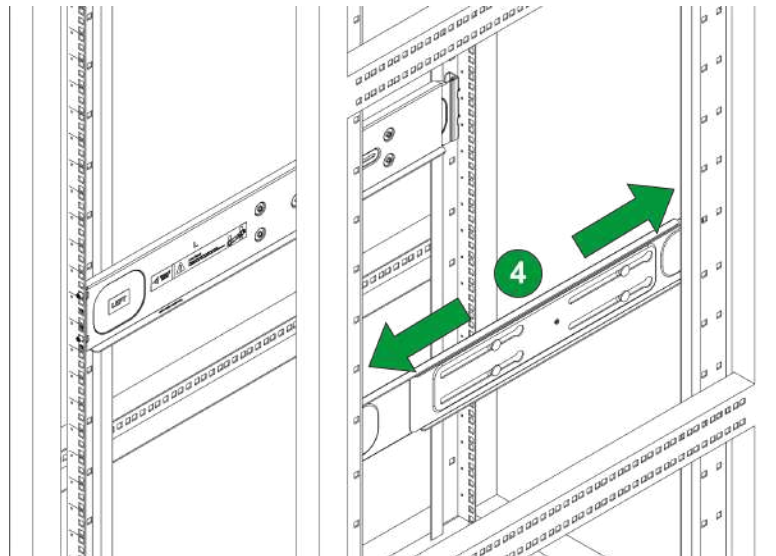

Figure 2-2. Securing the Rails to the Rack

5. (Optional step) Add the front left and right handles to the chassis using five screws to secure each handle. Install a thumbscrew through the bottom hole of each handle.

Note: These handles are optional and need only be installed when mounting the system into a short rack. When mounting into a deep rack, they are unnecessary and regular screws should be used instead of thumbscrews. These handles are not to be used for lifting the system, and are only to be used to slide the system within the rack.

6. With one person on either side (see the descriptive label on the side of the chassis), lift the system and slide it into the installed rails.

Important: Be sure that the system is empty of all CPU modules, storage modules, power supplies, PCIe modules, and the PCH module *before* lifting. These should be installed *after* the system is mounted in the rack. Injury and damage may occur if components are not removed from the rack prior to installation.

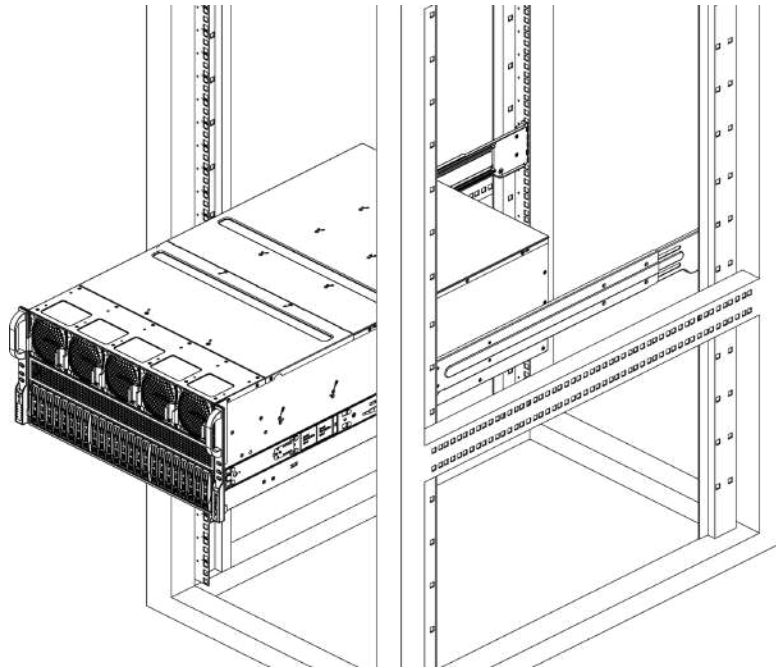

Figure 2-3. Installing the Chassis into the Rack

7. After pushing the chassis all the way into the rack, use two roundhead screws on each side of the chassis to lock it into place.
8. With the chassis now secure in the rack, the CPU modules, storage modules, power supplies, PCIe modules and the PCH module may all be installed in the chassis.

Chapter 3:

Maintenance and Component Installation

This chapter provides instructions on installing and replacing main system components for the AS -5126GS-TNRT/-TNRT2 server. To prevent compatibility issues, only use components that match the specifications and/or part numbers given.

Installation or replacement of most components require that power first be removed from the system. Follow the procedures given in each section.

3.1 Removing Power	37
3.2 Accessing the System	38
Removing the Middle Top Cover	38
Removing the Entire Top Cover	39
3.3 Static-Sensitive Devices	40
Precautions	40
3.4 Processor and Heatsink Installation	41
Preparing the Processor Socket	41
Installing the Processor into the Frame	43
Uninstalling the Heatsink and Processor	46
3.5 Memory Support and Installation	48
Memory Support	48
General Guidelines for Optimizing Memory Performance	48
DIMM Population	48
DIMM Installation	50
DIMM Removal	52
3.6 Motherboard Battery Removal and Installation	54
Battery Removal	54
Proper Battery Disposal	54
Battery Installation	54
3.7 Storage Drives	55
Removing a Hot-Swap Drive Carrier from the Chassis	55
Installing a Drive in a Carrier	55
Hot-Swap for NVMe Drives	56

3.8 System Cooling	58
Fans	58
Air Shrouds	59
3.9 Expansion Cards	61
Riser Cards	61
AIOM Card	64
3.10 Power Supply	65
Replacing the Power Supply	65

3.1 Removing Power

Use the following procedure to ensure that power has been removed from the AS -5126GS-TNRT/-TNRT2 server. This step is necessary when removing or installing non-hot-swap components or when replacing a non-redundant power supply.

1. Use the operating system to power down the system.
2. After the system has completely shut-down, disconnect the AC power cord(s) from the power strip or outlet. (If your system has more than one power supply, remove the AC power cords from all power supply modules.)
3. Disconnect the power cord(s) from the power supply module(s).

3.2 Accessing the System

The AS -5126GS-TNRT/-TNRT2 server features a removable top cover, which allows easy access to the inside of the server.

Removing the Middle Top Cover

Important: Except for short periods of time, do not operate the server without the cover in place. The chassis cover must be in place to allow for proper airflow and to prevent overheating.

1. Remove the two screws on each side of the middle top cover, which secure the cover to the chassis.
2. Lift the rear top cover up.
3. Check that all ventilation openings on the top cover and the top of the chassis are clear and unobstructed.

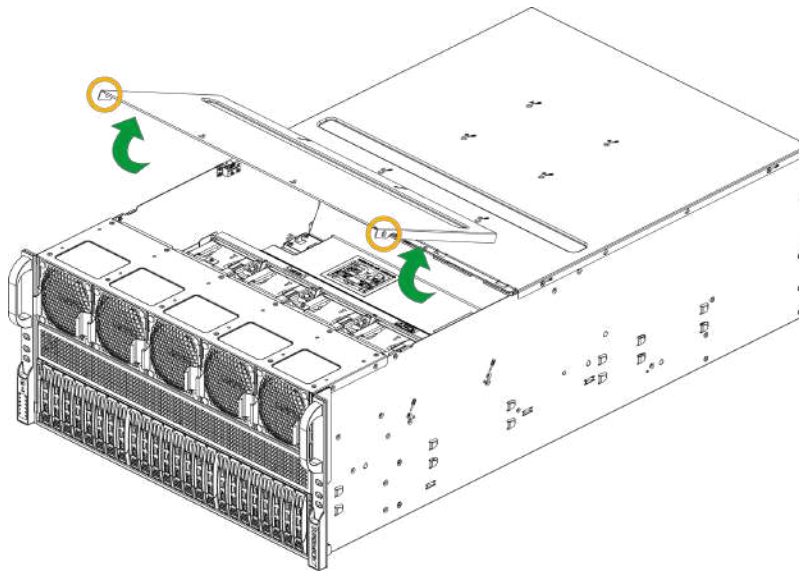

Figure 3-1. Removing the Middle Top Cover

Removing the Entire Top Cover

Important: Except for short periods of time, do not operate the server without the cover in place. The chassis cover must be in place to allow for proper airflow and to prevent overheating.

1. Remove the middle top cover as described above.
2. Remove any screws at the sides of the rear top cover.
3. Slide the rear top cover backward and lift the cover up.

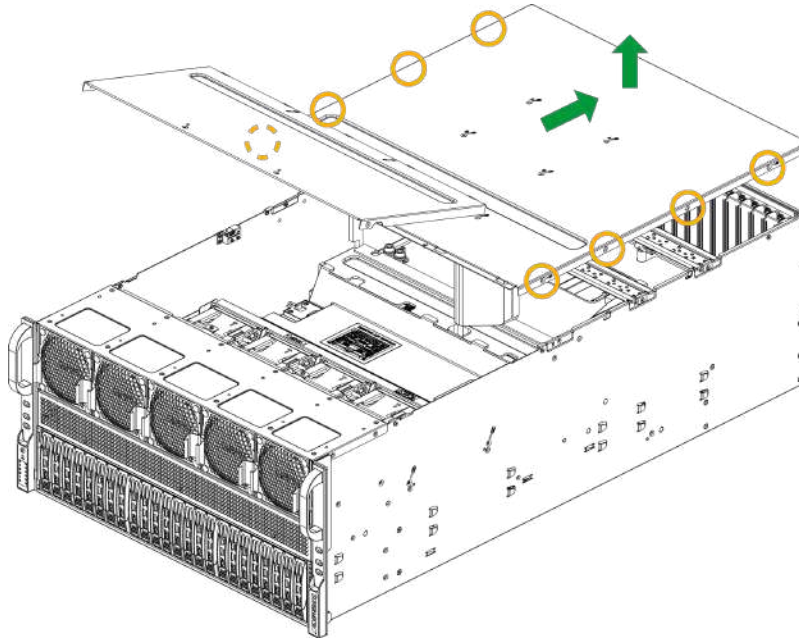

Figure 3-2. Removing the Entire Top Cover

3.3 Static-Sensitive Devices

Electrostatic Discharge (ESD) can damage electronic components. To avoid damaging your motherboard, it is important to handle it very carefully. The following measures are generally sufficient to protect your equipment from ESD.

Precautions

- Use a grounded wrist strap designed to prevent static discharge.
- Touch a grounded metal object before removing the board from the antistatic bag.
- Handle the motherboard only by its edges. Do not touch its components, peripheral chips, memory modules, or gold contacts.
- When handling chips or modules, avoid touching their pins.
- Put the motherboard and peripherals back into their antistatic bags when not in use.
- For grounding purposes, make sure that your computer chassis provides excellent conductivity between the power supply, the case, the mounting fasteners, and the motherboard.
- Use only the correct type of onboard CMOS battery. To avoid possible explosion, do not install the onboard battery upside down.

3.4 Processor and Heatsink Installation

This section provides procedures to install the processor(s) and heatsink(s).

Notes:

- Take industry standard precautions to avoid ESD damage. For details, see "[Static-Sensitive Devices](#)" on the previous page.
- Before starting, make sure that the plastic socket cap is in place and none of the socket pins are bent. If any damage is noted, contact your retailer.
- Do not connect the system power cord before the processor and heatsink installation is complete.
- When handling the processor, avoid touching or placing direct pressure on the LGA lands (gold contacts). Improper installation or socket misalignment can cause serious damage to the processor or processor socket.
- When buying a processor separately, use only a Supermicro certified heatsink.
- Refer to the Supermicro website for the most recent processor support.
- When installing the heatsink, ensure a torque driver set to the correct force is used for each screw.
- Thermal grease is pre-applied on a new heatsink. No additional thermal grease is needed.

Preparing the Processor Socket

1. Remove the screw holding down the force frame. The spring-loaded force frame will raise up. Allow it to lift up to its stopped position.

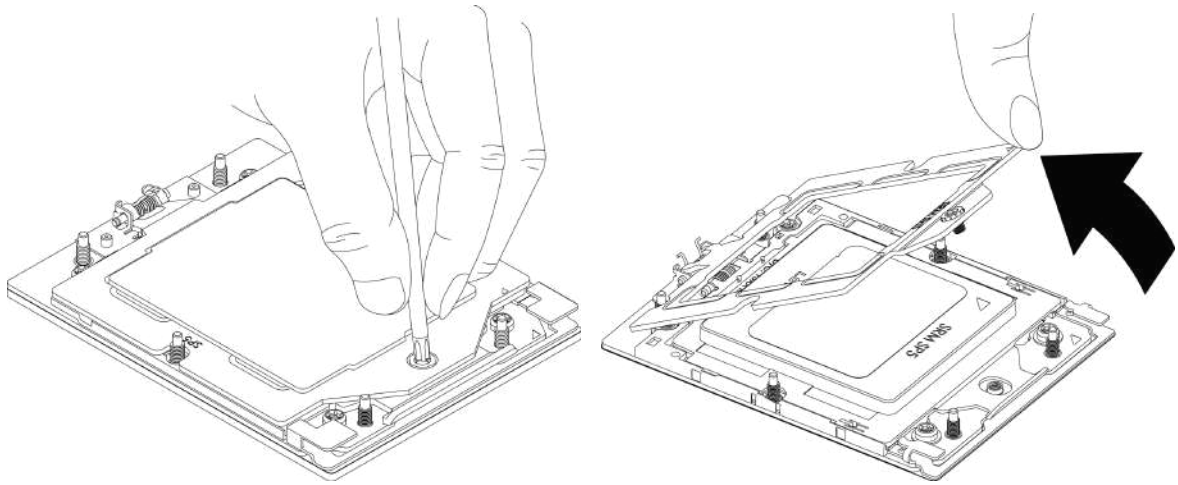

Figure 3-3. Removing Screw from the Force Frame

2. Lift the rail frame up by gripping the lift tabs near the front end of the rail frame. While keeping a secure grip of the rail frame, lift it to a position so you can do the next step of removing the external cap.

Note: The rail frame is spring loaded, so keep a secure grip on it as you lift it so it does not snap up.

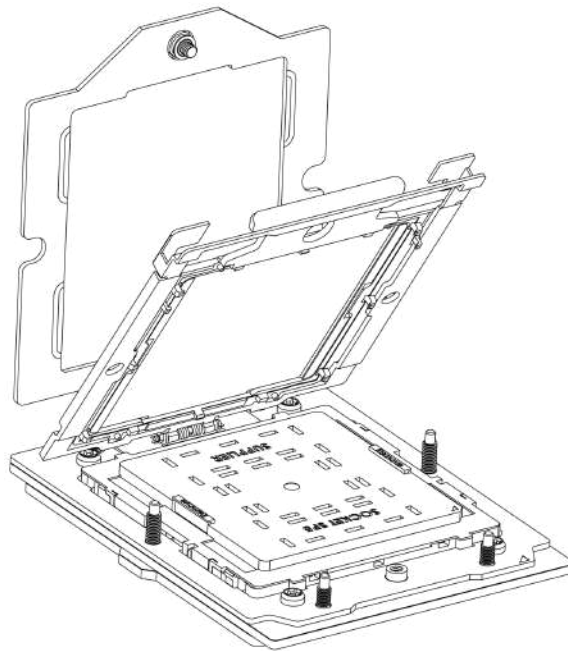

Figure 3-4. Lifting the Frame

3. Remove the external cap from the rail frame by pulling it upwards through the rail guides on the rail frame.

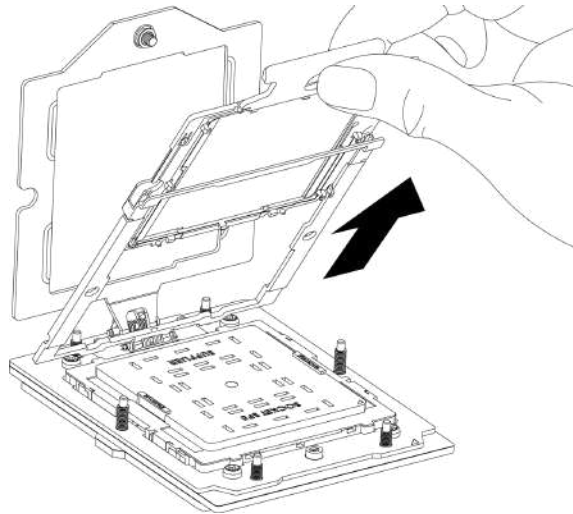

Figure 3-5. Removing the Cap

Installing the Processor into the Frame

1. The processor package is shipped from the factory with the carrier frame pre-assembled. Grip the handle of the carrier frame/processor assembly from its shipping tray, and while gripping the handle, align the flanges of the carrier frame onto the rails of the rail frame so its pins will be at the bottom when the rail frame is lowered later.
2. Slide the carrier frame/processor assembly downwards to the bottom of the rail frame. Ensure the flanges are secure on the rails as you lower it downwards.

Note: You can only install the processor inside the socket in one direction with the handle at the top. Make sure that it is properly inserted into the socket before closing the rail frame plate. If it doesn't close properly, do not force it as it may damage your processor. Instead, open the rail frame plate again, and double-check that the processor is aligned properly.

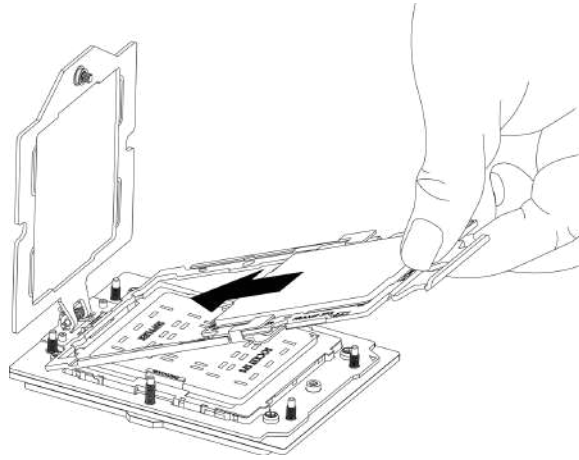

Figure 3-6. Installing into the Rail Frame

3. Lift up the rail frame until it securely rests in upright position. Then remove the cover cap from the socket below. Grip the two lift tabs marked "Remove" at the middle of the cap and pull vertically upwards to remove the cover cap.

Important: The exposed socket contacts are extremely vulnerable and can be damaged easily. Do not touch or drop objects onto the contacts and be careful removing the cover cap and when placing the rail frame over the socket.

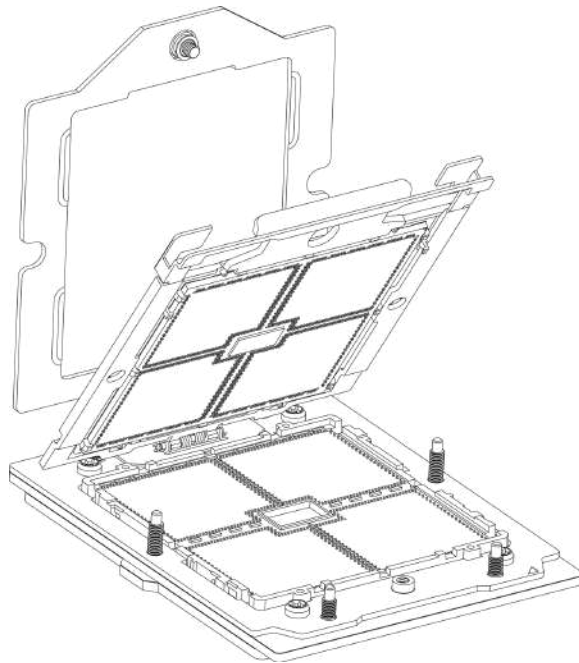

Figure 3-7. Removing the Cover Cap

4. Gently lower the rail frame down onto the socket until the latches on the rail frame engage with the socket housing and it rests in place. Do not force it into place! Note that the force frame is spring loaded and must be held in place before it is secured.

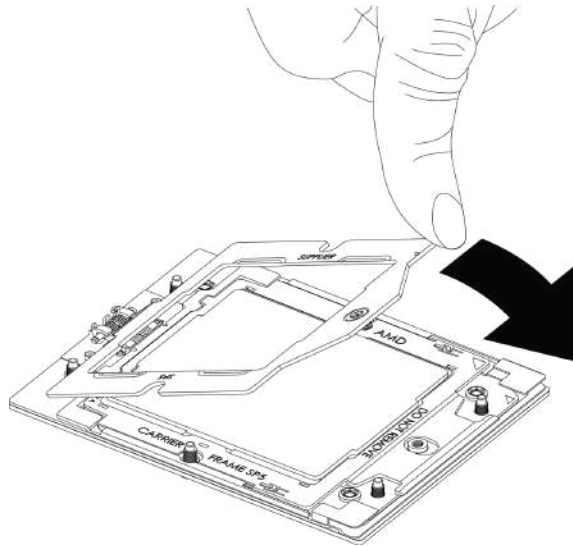

Figure 3-8. Securing the Force Frame

5. Use a T20 bit torque driver, set at 12.5–15.0 kgf-cm (10.8–13.0 in-lbf) to prevent damage to the processor. Replace and tighten the screws in the same order they were removed. When finished, the force frame will be secure over both the rail frame and processor package.

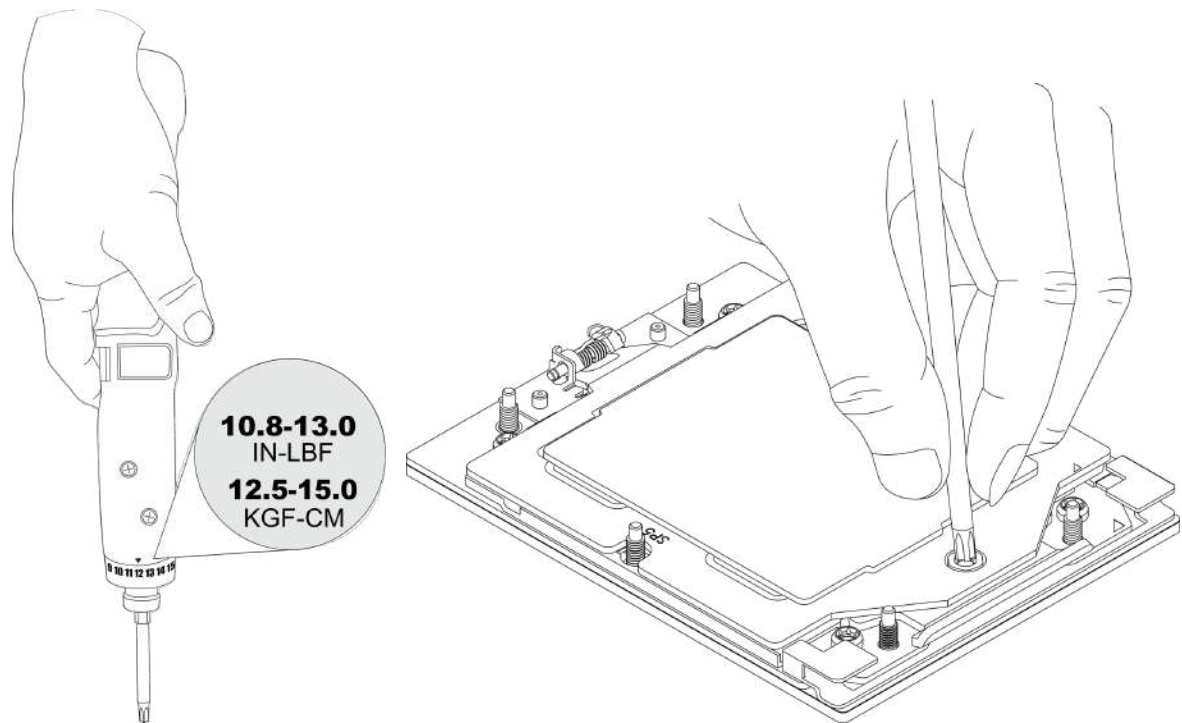

Figure 3-9. Replacing Screws with Torque Driver

Uninstalling the Heatsink and Processor

1. Remove the screws holding the heatsink and gently work it loose.
2. Clean the thermal grease left by the heatsink on the processor assembly to limit the risk of contaminating the land pads or contacts in the socket housing.
3. Unscrew the plate and lift the force frame to the vertical position.
4. Lift the rail frame using the lift tabs near the front end of the rail frame. Note that the rail frame is spring loaded, so be careful lifting it up into a vertical position.
5. Grip the handle of the carrier frame and pull upwards to extract it from the rail frame. Return the processor assembly to its original shipping container.
6. Grip the handle on the external cap and return it to the rail frame, sliding it downwards until it rests in the frame.
7. Gripping the rail frame, rotate it downwards until it rests above and locks over the socket housing in its horizontal position.
8. Push and rotate down the force frame until it is over the external cap and rail frame in a horizontal position.

9. While holding down the force frame, secure it back to the socket frame by securing screw #1 in place.

3.5 Memory Support and Installation

Important: To prevent any damage, exercise extreme care when installing or removing memory modules.

Note: Check the Supermicro website for recommended memory modules.

Memory Support

The AS -5126GS-TNRT/-TNRT2 supports up to 6 TB of ECC DDR5 RDIMM/3DS memory in 24 DIMM slots.

General Guidelines for Optimizing Memory Performance

- It is recommended to use DDR5 memory of the same type, size, and speed.
- Mixed DIMM speeds can be installed. However, all DIMMs will run at the speed of the slowest DIMM.
- The motherboard will support an odd number amount of memory modules. However, to achieve the best memory performance, a balanced memory population is recommended.

DIMM Population

This table shows the recommended slots to populate.

DIMM Population Guide for Dual CPUs														
Type	Channel													Nodes per Socket (NPS) Supported
	F1	E1	D1	C1	B1	A1	G1	H1	I1	J1	K1	L1		
2 CPUs and 2 DIMMs	CPU1						V							NPS1
	CPU2						V							
2 CPUs and 4 DIMMs	CPU1						V	V						NPS2, NPS1
	CPU2						V	V						
2 CPUs and 8 DIMMs	CPU1				V		V	V		V				NPS4, NPS2, NPS1
	CPU2				V		V	V		V				
2 CPUs and 12 DIMMs	CPU1				V	V	V	V	V	V				NPS2, NPS1
	CPU2				V	V	V	V	V	V				
2 CPUs and 16 DIMMs	CPU1		V		V	V	V	V	V	V		V		NPS4, NPS2, NPS1
	CPU2		V		V	V	V	V	V	V		V		
2 CPUs and 20 DIMMs	CPU1		V	V	V	V	V	V	V	V	V	V		NPS2, NPS1
	CPU2		V	V	V	V	V	V	V	V	V	V		
2 CPUs and 24 DIMMs	CPU1	V	V	V	V	V	V	V	V	V	V	V	V	NPS4, NPS2, NPS1
	CPU2	V	V	V	V	V	V	V	V	V	V	V	V	

Note: Fully populate the motherboard with validated memory modules to achieve optimal memory performance. The NPS setting depends on the application. Selecting Auto in the BIOS defaults to NPS1.

Populating RDIMM / 3DS DDR5 Memory Modules with AMD EPYC™ 9004 Series Processor			
Type	DIMM Population	Maximum Frequency (MT/s)Frequency	
		DIMM1	5600 MT/s Grade DIMM
RDIMM	1R	4800	4800
	2R	4800	4800
3DS RDIMM	2S2R (4 ranks)	4800	4800
	2S4R (8 ranks)	4800	4800

Populating RDIMM / 3DS DDR5 Memory Modules with AMD EPYC™ 9005 Series Processor				
DIMM Type	DIMM Population	Maximum Frequency (MT/s)Frequency		
		DIMM1	6400 MT/s Grade DIMM	5600 MT/s Grade DIMM

Populating RDIMM / 3DS DDR5 Memory Modules with AMD EPYC™ 9005 Series Processor				
RDIMM	1R	6400	4800	4800
	2R	6400	4800	4800
3DS RDIMM	2S2R (4 ranks)	6400	4800	4800
	2S4R (8 ranks)	6400	4800	4800

Figure 3-10. DIMM Population Guide

Note: 6400 MT/s memory speed and performance may vary depending on the memory DIMM model. Use Supermicro validated memory for optimal results. Contact your Supermicro representative for more details.

DIMM Installation

Important: To avoid causing any damage to the memory module or the DIMM socket, do not use excessive force when pressing the release tabs on the ends of the DIMM socket. Handle memory modules with care. To avoid ESD-related damage to your memory modules or components, carefully follow all the instructions given in ["Static-Sensitive Devices"](#) on page 40.

1. Insert the desired number of DIMMs into the memory slots based on the recommended DIMM population table earlier in this section.
2. Push the release tabs outwards on both ends of the DIMM slot to unlock it.

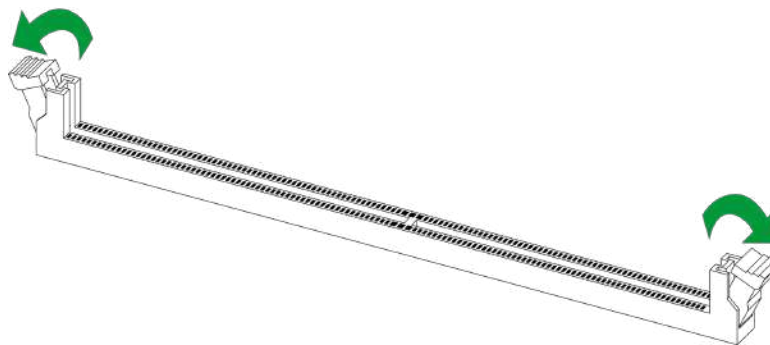

Figure 3-11. Unlocking the DIMM Slot

3. Align the key of the DIMM with the receptive point on the memory slot.

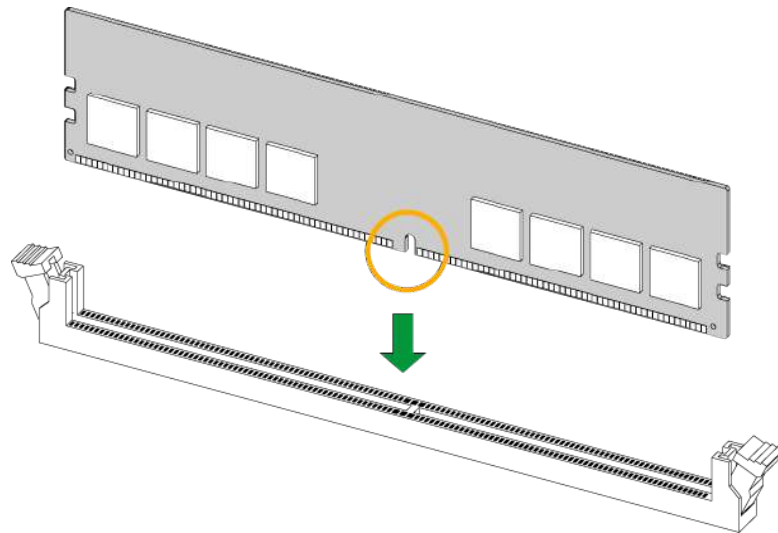

Figure 3-12. Aligning the DIMM Slot with the Receptive Point

4. Align the notches on both ends of the module against the receptive points on the ends of the slot.

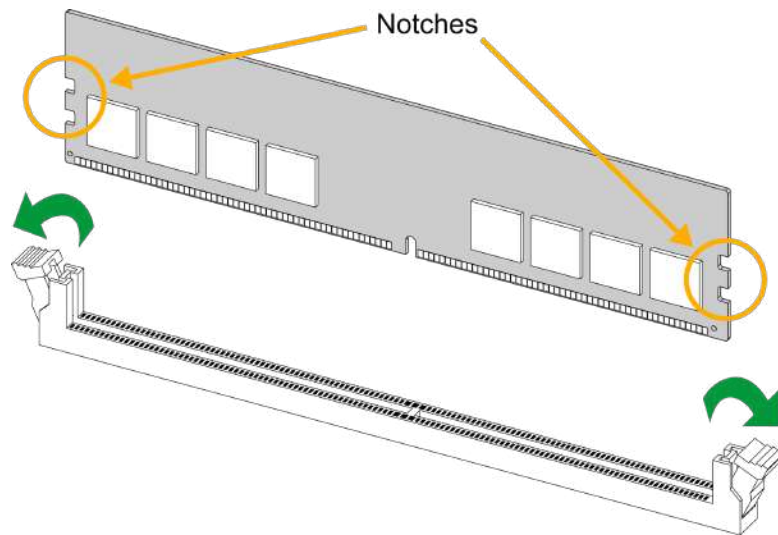

Figure 3-13. Aligning the Notches

5. Press both ends of the module straight down into the slot until the module snaps into place.
6. Press the release tabs to the lock positions to secure the DIMM into the slot.

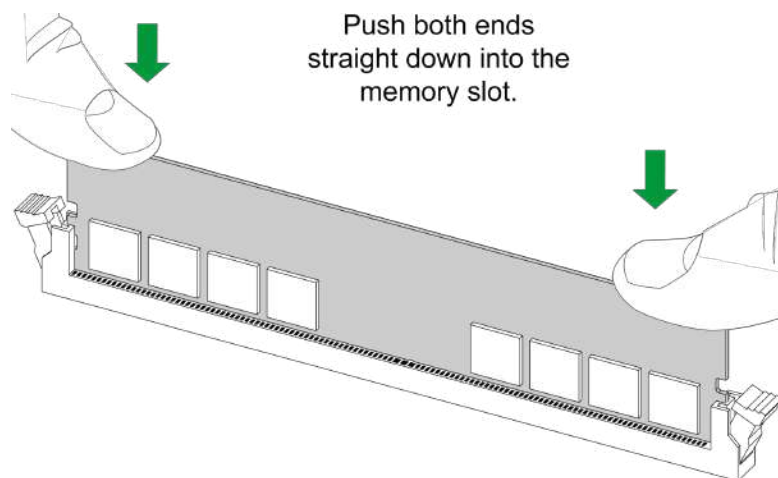

Figure 3-14. Securing the DIMM

For a detailed diagram of the H14DSG-O-CPU motherboard, see the layout under "[Motherboard Quick Reference](#)" on page 24.

DIMM Removal

Important: To avoid causing any damage to the memory module or the DIMM socket, do not use excessive force when pressing the release tabs on the ends of the DIMM socket. Handle memory modules with care. To avoid ESD-related damage to your memory modules or components, carefully follow all the instructions given in "[Static-Sensitive Devices](#)" on page 40.

Press both release tabs on the ends of the DIMM socket to unlock it. Once the DIMM is loosened, remove it from the memory slot.

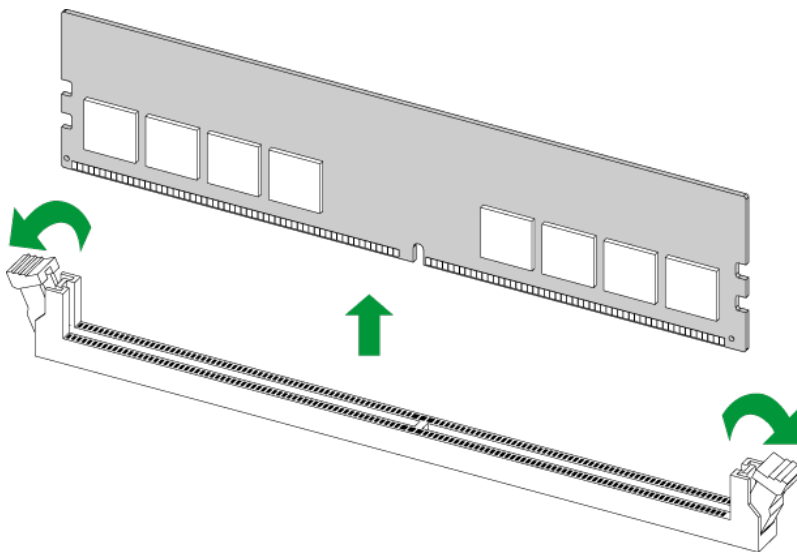

Figure 3-15. Unlocking the DIMM Slot

For a detailed diagram of the H14DSG-O-CPU motherboard, see the layout under ["Motherboard Quick Reference"](#) on page 24.

3.6 Motherboard Battery Removal and Installation

Battery Removal

To remove the onboard battery, follow the steps below:

1. Power off your system and unplug your power cable.
2. Locate the onboard battery as shown below.
3. Using a tool such as a pen or a small screwdriver, push the battery lock outwards to unlock it. Once unlocked, the battery will pop out from the holder.
4. Remove the battery.

Proper Battery Disposal

Important: Handle used batteries carefully. Do not damage the battery in any way; a damaged battery may release hazardous materials into the environment. Do not discard a used battery in the garbage or a public landfill. Comply with the regulations set up by your local hazardous waste management agency to dispose of your used battery properly.

Battery Installation

To install an onboard battery, follow steps 1 and 2 above and continue below:

Important: When replacing a battery, be sure to only replace it with the same type.

1. Identify the battery's polarity. The positive (+) side should be facing up.
2. Insert the battery into the battery holder and push it down until you hear a click to ensure that the battery is securely locked.

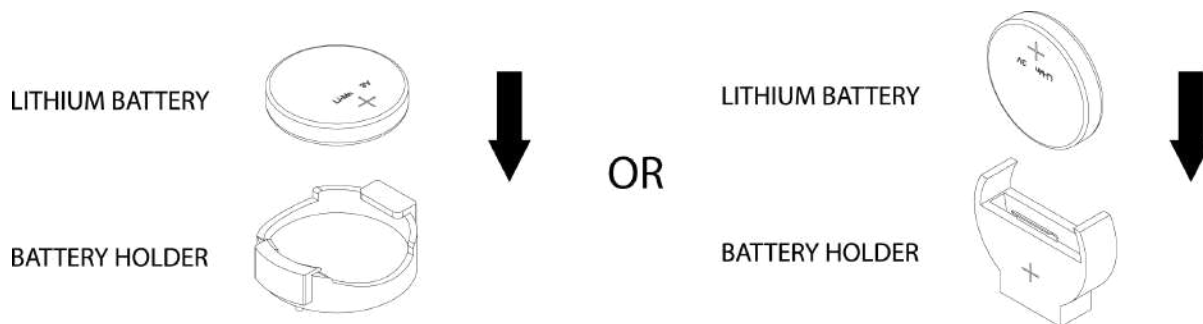

Figure 3-16. Installing a Battery

3.7 Storage Drives

The AS -5126GS-TNRT/-TNRT2 server supports up to 24 2.5" storage drives.

Note: Enterprise-level storage modules are recommended for use in Supermicro servers.

Removing a Hot-Swap Drive Carrier from the Chassis

1. Press the release button on the drive carrier, which will extend the drive carrier handle.
2. Use the drive carrier handle to pull the drive out of the chassis.

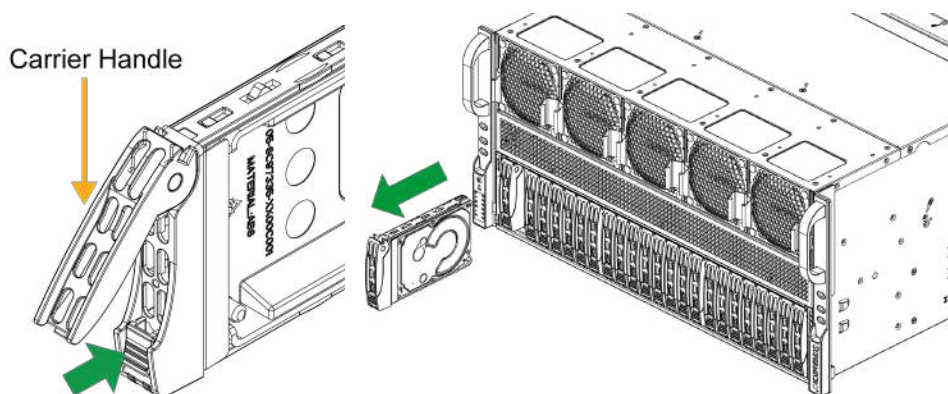

Figure 3-17. Removing a Drive Carrier

Installing a Drive in a Carrier

1. Remove the dummy drive, which comes pre-installed in the drive carrier. Pull out the two locking clasps on the left outside of the carrier and lift out the dummy drive.
2. Install the drive directly into the tray and push in the two locking clasps to secure the drive in place.
3. Insert the drive carrier into its bay, keeping the release button on the right. When the carrier reaches the rear of the bay, the release handle will retract. Push the handle in until it clicks into its locked position.

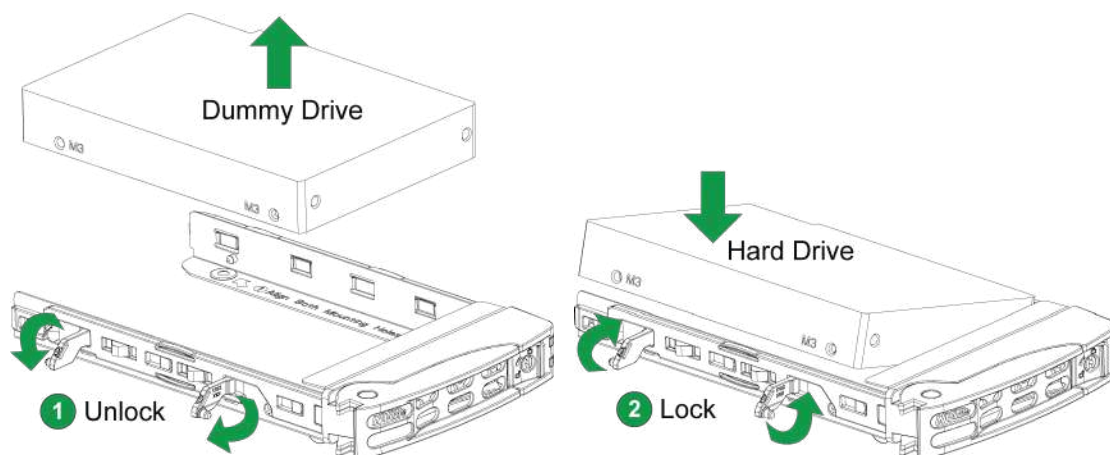

Figure 3-18. Installing a Storage Drive in a Carrier

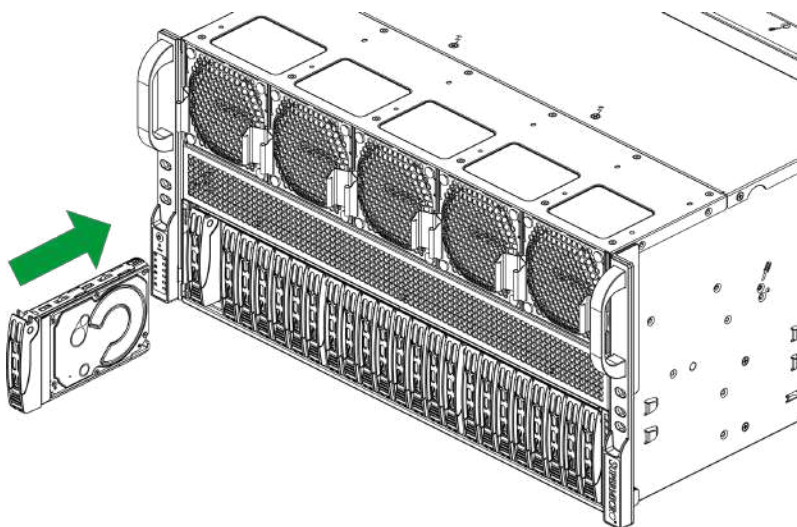

Figure 3-19. Installing a Drive Carrier into the System

Hot-Swap for NVMe Drives

Supermicro servers support NVMe surprise hot-swap. For even better data security, NVMe orderly hot-swap is recommended. NVMe drives can be ejected and replaced remotely using BMC.

Note: If you are using VROC, see the VROC appendix in this manual instead.

Ejecting a Drive

1. Go to **BMC > Server Health > NVMe SSD**.
2. Select **Device**, **Group**, and **Slot**.

3. Click **Eject**. After ejecting, the drive Status LED indicator turns green.
4. Remove the drive.

Note that **Device** and **Group** are categorized by the CPLD design architecture. The AS - 5126GS-TNRT/-TNRT2 server has one Device and one Group.

Slot is the slot number on which the NVMe drives are mounted.

Replacing a Drive

1. Insert the replacement drive.
2. Go to **BMC > System > Storage Monitor > Physical View**.
3. Select **Device**, **Group**, and **Slot**.
4. Click **Insert**. The drive Status LED indicator flashes red, then turns off. The Activity LED turns blue.

3.8 System Cooling

Refer to the following sections for information about the cooling capabilities of the AS -5126GS-TNRT/-TNRT2 server.

Fans

The AS -5126GS-TNRT/-TNRT2 server contains five external and five internal 8-cm high-performance fans.

Fan speed is controlled by a system temperature setting in the BMC. If a fan fails, the remaining fans will ramp up to full speed. The system can continue to run with a failed fan. Replace any failed fan at your earliest convenience with the same type and model. Failed fans can be identified through the BMC.

Changing a System Fan

1. If replacing an internal fan, remove the middle top cover as described in ["Accessing the System" on page 38](#).
2. Remove the housing of the failed fan from the chassis:
 - For an external fan, pinch the side clamps of the housing and remove from the chassis.
 - For an internal fan, lift the housing from the chassis.
3. In the removed housing, replace the failed fan with an identical fan, available from Supermicro.
4. Push the new fan into the housing, making sure the air flow direction is the same.
5. Return the housing with the new fan into the chassis.
6. Power up the system and check that the fan is working properly and that the LED on the control panel has turned off. Finish by replacing the chassis cover, if applicable.

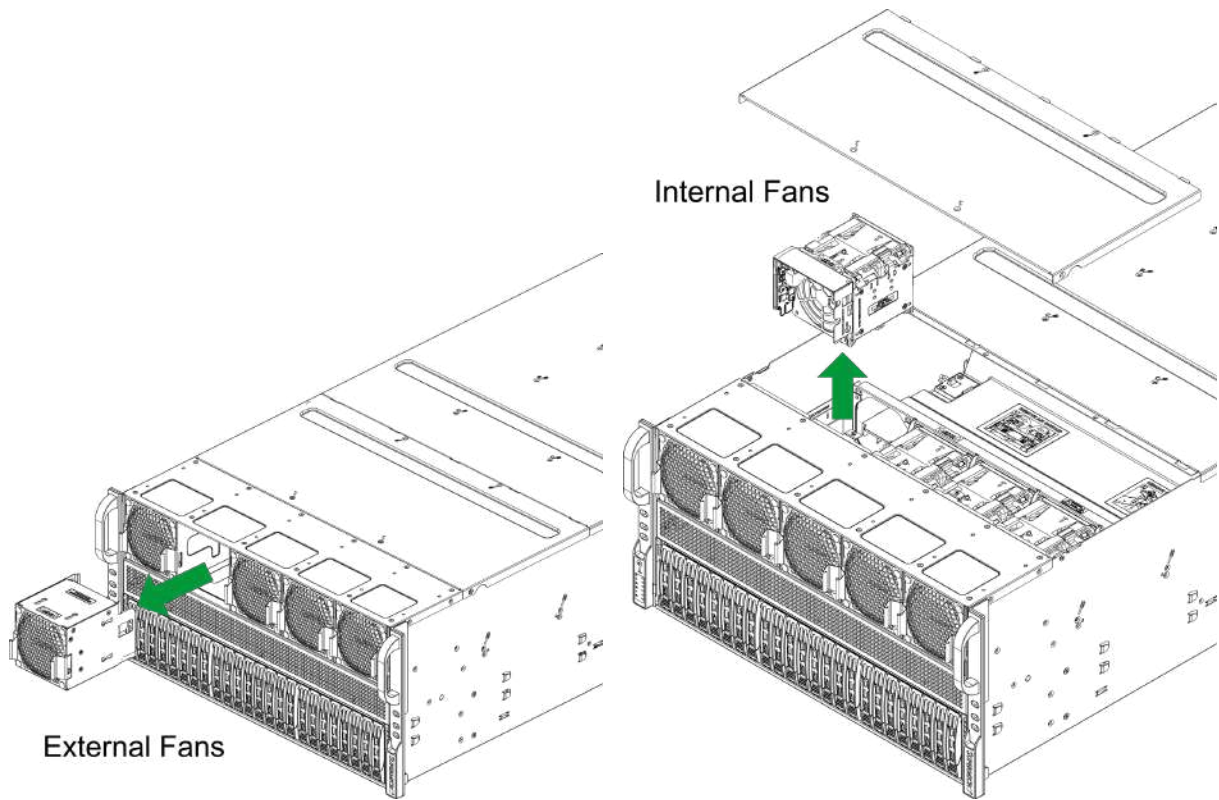

Figure 3-20. Changing a System Fan

Air Shrouds

Air shrouds concentrate airflow to maximize fan efficiency. They do not require screws to install.

Installing an Air Shroud

1. Position the air shrouds as illustrated in the figure below.

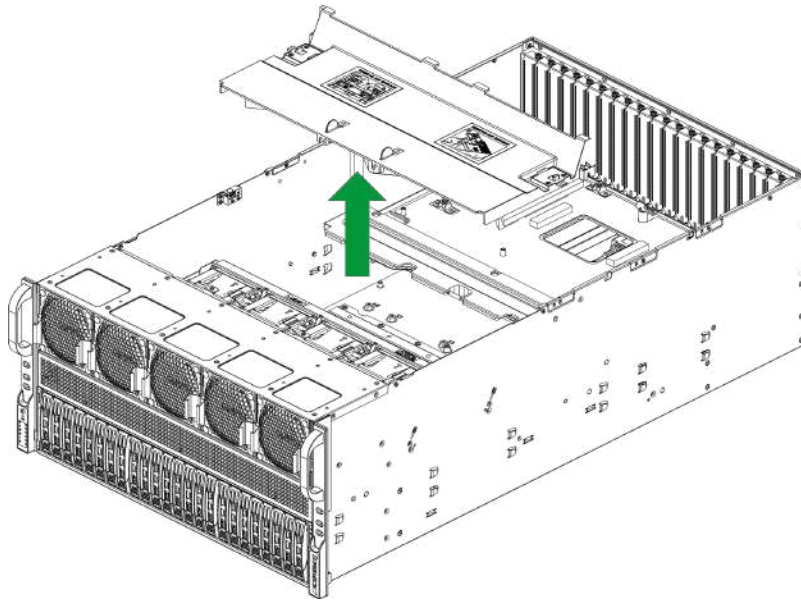

Figure 3-21. Installing an Air Shroud

3.9 Expansion Cards

Refer to the following sections for information on the expansion cards supported by the AS -5126GS-TNRT/-TNRT2 server.

Riser Cards

The AS -5126GS-TNRT supports nine PCIe 5.0 cards and AS -5126GS-TNRT2 supports 13 PCIe 5.0 cards.

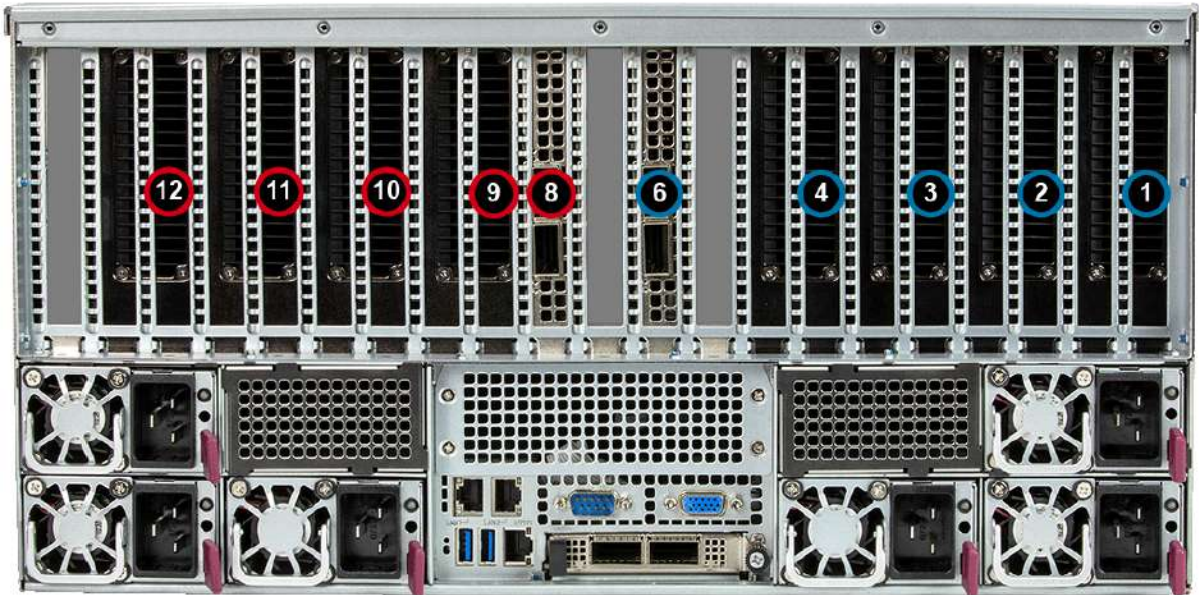
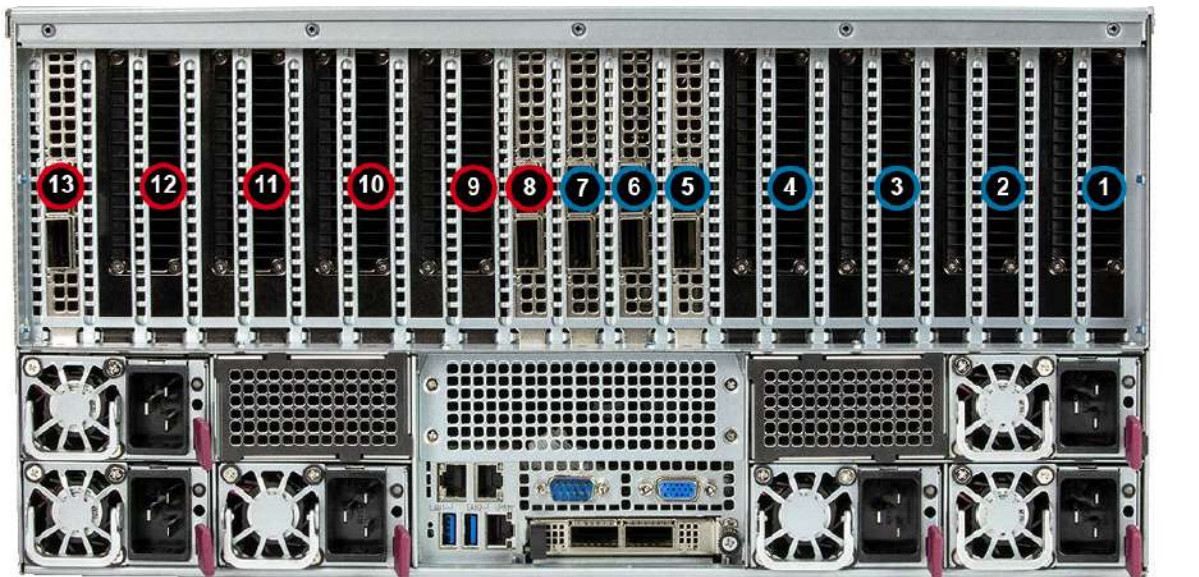

Figure 3-22. AS -5126GS-TNRT Expansion Card Slots



● CPU1 ● CPU2

Figure 3-23. AS -5126GS-TNRT2 Expansion Card Slots

Expansion Slot Locations		
System SKU	Item	Description
AS -5126GS-TNRT	1-4, 6, 9-12	PCIe 5.0 x16 (full-height, full-length)
	8	PCIe 5.0 x16 or x8 (full-height, full-length)
AS -5126GS-TNRT2	1-13	PCIe 5.0 x16 (full-height, full-length)
In AS -5126GS-TNRT, slot 8 supports PCIe lanes based on the NVMe drive bay configuration.		

Installing Expansion Cards

1. Turn off system power as described in [Removing Power](#).
2. Remove the top cover as described in ["Accessing the System" on page 38](#).
3. Install expansion cards into the PCIe slot and secure with a screw.
4. Connect any cables.
5. Reinstall the cover and power up the system.

AIOM Card

The AS -5126GS-TNRT2 supports one AIOM/OCP 3.0 card.



Figure 3-24. AS -5126GS-TNRT2 AIOM Card Slot

AIOM Slot Location		
System SKU	Item	Description
AS -5126GS-TNRT2	14	PCIe 5.0 x16 AIOM (OCP 3.0)

Installing AIOM

1. Remove the blank cover plate (14) by unscrewing the thumbscrew.
2. Slide the AIOM card in the opening until it seats in the motherboard slot.
3. Secure with the thumbscrew.

3.10 Power Supply

The system includes two redundant power supply modules. If a power supply must be replaced, the system doesn't need to be shut off. On the rear of the power supply module, an LED displays the power status.

Information LED	
Color	Description
Green, solid	When illuminated, indicates that the power supply is on.
Green, blinking	When blinking, indicates that the power supply is plugged in and turned off by the system.
Amber, blinking	When blinking, indicates that the power supply has a warning condition and continues to operate.
Amber, solid	When illuminated, indicates that the power supply is plugged in, and is in an abnormal state. The system might need service. Contact Supermicro technical support.

Replacing the Power Supply

1. Unplug the AC cord from the module to be replaced.
2. Push the release tab on the back of the power supply as illustrated.
3. Pull the power supply out using the handle.
4. Replace the failed power module with the same model.
5. Push the new power supply module into the power bay until it clicks.
6. Plug the AC power cord back into the module.

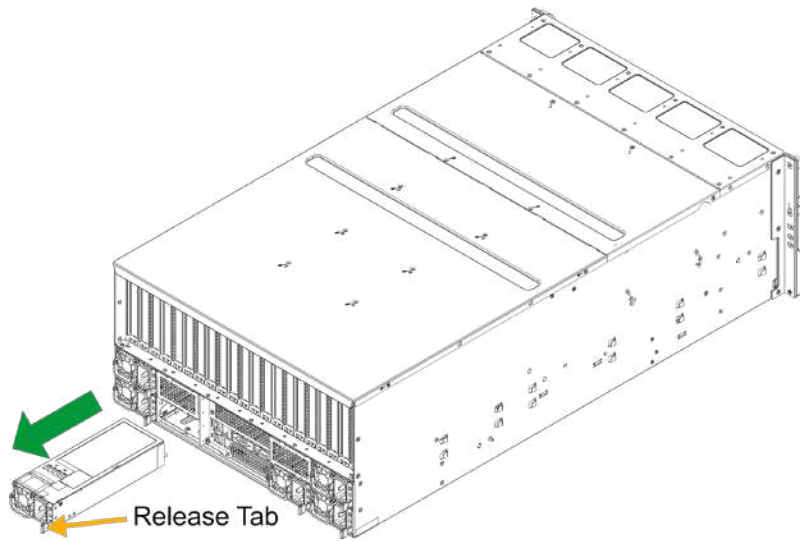

Figure 3-25. Replacing the Power Supply

Chapter 4:

Motherboard Connections, Jumpers, and LEDs

This section describes the connections on the motherboard and provides pinout definitions. Note that depending on how the system is configured, not all connections are required. The LEDs on the motherboard are also described here. A motherboard layout indicating component locations may be found in the ["Introduction" on page 11](#). More detail can be found in the H14DSG-O-CPU motherboard manual.

Review the ["Standardized Warning Statements for AC Systems" on page 133](#) before installing or removing components.

4.1 Power Connectors	68
4.2 Headers and Connections	69
Chassis Intrusion	69
NC-SI Connection	69
TPM/Port 80 Header	69
4.3 Jumper Settings	71
CMOS Clear	71
UID LED and System_Reset Button Select Jumper	72
4.4 LED Indicators	73
BMC Heartbeat LED	73
M.2 LEDs	73
Onboard Power LED	73
Unit ID (UID) LED	74

4.1 Power Connectors

Four power supply connections, located at PSU1, PSU2, PSU3, and PSU4, provide main power to the system. In addition, JPWR1–JPWR6 are 12 V 8-pin power connectors.

JPWR1–JPWR6 8-pin Power Pin Definitions	
Pin#	Definition
1–4	GND
5–8	12 V

4.2 Headers and Connections

For information about the headers on the H14DSG-O-CPU motherboard, refer to the following content.

Chassis Intrusion

A Chassis Intrusion header is located at JL1 on the H14DSG-O-CPU motherboard. Attach the appropriate cable from the chassis to inform you when the chassis is opened.

For a detailed diagram of the H14DSG-O-CPU motherboard, see the layout under "[Motherboard Quick Reference](#)" on page 24.

Chassis Intrusion	
Pin Definitions: Two Total	
Pin#	Definition
1	Intrusion Input
2	GND

NC-SI Connection

The Network Controller Sideband Interface (NC-SI) connection is located on the H14DSG-O-CPU motherboard. This connection is used to connect a Network Interface Card (NIC) to the motherboard to allow the onboard Baseboard Management Controller (BMC) to communicate with a network.

Note: For detailed instructions on how to configure Network Interface Card (NIC) settings, refer to the Network Interface Card Configuration User's Guide posted on the web page under the link: <https://www.supermicro.com/support/manuals>.

For a detailed diagram of the H14DSG-O-CPU motherboard, see the layout under "[Motherboard Quick Reference](#)" on page 24.

TPM/Port 80 Header

The JTPM1 header on the H14DSG-O-CPU motherboard is used to connect a Trusted Platform Module (TPM)/Port 80, which is available from Supermicro (optional). A TPM/Port 80 connector is a security device that supports encryption and authentication in storage drives. It allows the motherboard to deny access if the TPM associated with the storage drive is not installed in the system. Information on the TPM is available at the following page:

https://www.supermicro.com/manuals/other/AOM-TPM-9670V_9670H_X12_H12.pdf

For a detailed diagram of the H14DSG-O-CPU motherboard, see the layout under ["Motherboard Quick Reference" on page 24](#).

Trusted Platform Module Header			
Pin Definitions: 10 Total			
Pin#	Definition	Pin#	Definition
1	+3.3 V	2	SPI_CS#
3	RESET#	4	SPI_MISO
5	SPI_CLK	6	Ground
7	SPI_MOSI	8	No Connection
9	+1.8 V Standby	10	SPI_IRQ#

4.3 Jumper Settings

To modify the operation of the motherboard, jumpers can be used to choose between optional settings. Jumpers create shorts between two pins to change the function of the connector. Pin 1 is identified with a square solder pad on the printed circuit board. See the diagram below for an example of jumping pins 1 and 2. Refer to the motherboard layout page for jumper locations.

Note: On two-pin jumpers, "Closed" means the jumper is on and "Open" means the jumper is off the pins.

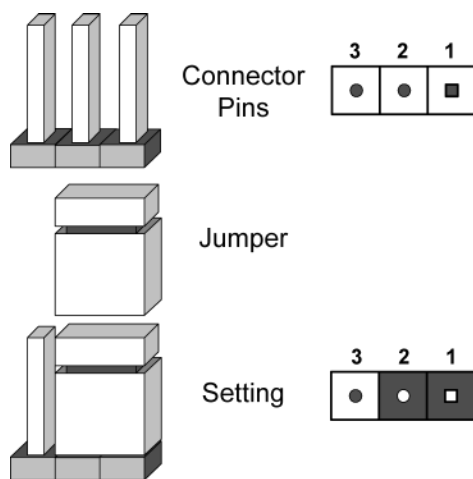

Figure 4-1. Jumping Connector Pins

CMOS Clear

JBT1 on the H14DSG-O-CPU motherboard is used to clear CMOS, which will also clear any passwords. Instead of pins, this jumper consists of contact pads to prevent accidentally clearing the contents of CMOS.

For a detailed diagram of the H14DSG-O-CPU motherboard, see the layout under ["Motherboard Quick Reference" on page 24](#).



1. First power down the system and unplug the power cord(s).
2. Remove the cover of the chassis to access the motherboard.
3. Remove the onboard battery from the motherboard.

4. Short the CMOS pads, JBT1, with a metal object such as a small screwdriver for at least four seconds.

Note: Clearing CMOS will also clear all passwords.

5. Remove the screwdriver (or shorting device).
6. Replace the cover, reconnect the power cord(s), and power on the system.

UID LED and System_Reset Button Select Jumper

For a detailed diagram of the H14DSG- O-CPU motherboard, see the layout under "[Motherboard Quick Reference](#)" on page 24.

4.4 LED Indicators

For information about the LED indicators on the AS -5126GS-TNRT/-TNRT2 server, refer to the following content.

BMC Heartbeat LED

A BMC Heartbeat LED is located on the H14DSG-O-CPU motherboard. When this LED is blinking, the BMC is functioning normally.

For a detailed diagram of the H14DSG-O-CPU motherboard, see the layout under ["Motherboard Quick Reference" on page 24](#).

BMC Heartbeat LED Indicator	
LED Color	Definition
Green: Blinking	BMC Normal

M.2 LEDs

M.2 LEDs are located on the H14DSG-O-CPU motherboard. When these LEDs are blinking, the M.2 devices are functioning normally.

For a detailed diagram of the H14DSG-O-CPU motherboard, see the layout under ["Motherboard Quick Reference" on page 24](#).

M.2 LED State	
LED Color	Definition
Green: Blinking	Device Working

Onboard Power LED

The Onboard Power LED is located on the H14DSG-O-CPU motherboard. When this LED is on, the system is on. Be sure to turn off the system and unplug the power cord before removing or installing components.

For a detailed diagram of the H14DSG-O-CPU motherboard, see the layout under ["Motherboard Quick Reference" on page 24](#).

Onboard Power LED Indicator	
LED Color	Definition
Off	System Power Off (power cable not connected)
Green	System Power On

Unit ID (UID) LED

The UID LED indicator is located on the H14DSG-O-CPU motherboard. This UID indicator provides easy identification of a system that may need to be serviced.

For a detailed diagram of the H14DSG- O- CPU motherboard, see the layout under "[Motherboard Quick Reference](#)" on page 24.

UID LED	
LED Indicator	
LED Color	Definitions
Blue: On	System Identified

Chapter 5:

Software

After the AS -5126GS-TNRT/-TNRT2 server has been installed, you can install the Operating System (OS), configure RAID settings, and install the drivers.

5.1 Microsoft Windows OS Installation	76
Installing the OS	76
Driver Installation	77
5.2 BMC	79
BMC ADMIN User Password	79
Logging into the BMC	79

5.1 Microsoft Windows OS Installation

If you will be using RAID, you must configure RAID settings before installing the Windows OS and the RAID driver. Refer to the RAID Configuration User Guides posted on our website at <https://www.supermicro.com/support/manuals>.

Installing the OS

1. Create a method to access the Microsoft Windows installation ISO file. That can be a USB flash or media drive, or the BMC KVM console.
2. Retrieve the proper drivers. Go to the Supermicro web page for your motherboard and click on "Download the Latest Drivers and Utilities," select the proper driver, and copy it to a USB flash drive.
3. Boot from a bootable device with Windows OS installation. You can see a bootable device list by pressing <F11> during the system bootup.

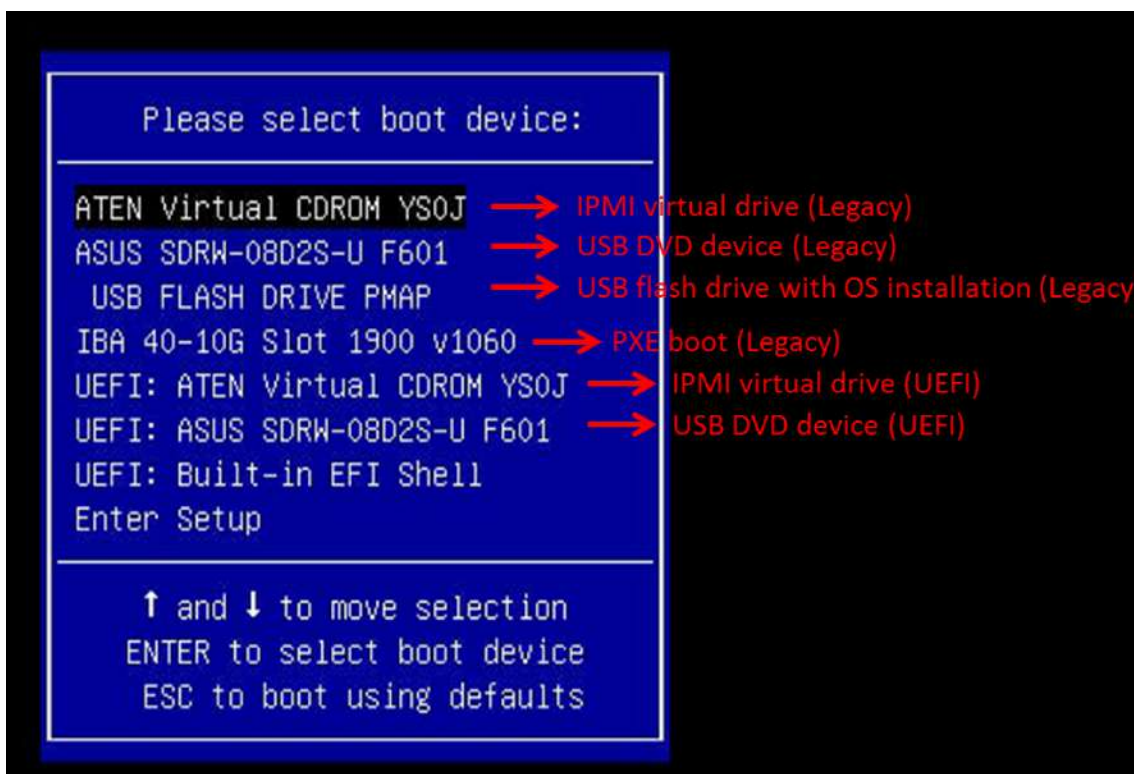

Figure 5-1. Selecting the Boot Device

4. During Windows Setup, continue to the dialog box where you select the drives on which to install Windows. If the disk you want to use is not listed, click on the "Load driver" link at the bottom left corner.

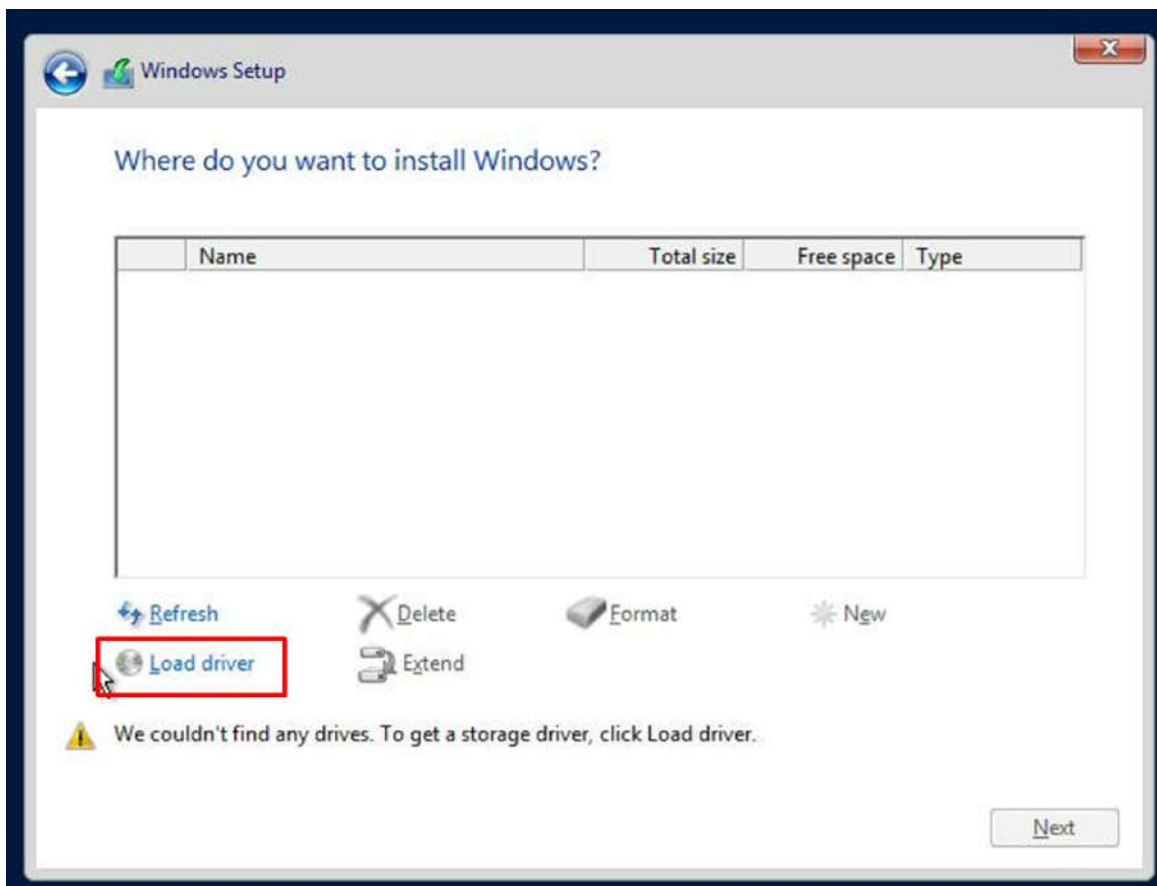

Figure 5-2. Loading the Driver Link

To load the driver, browse the USB flash drive for the proper driver files.

5. Once all devices are specified, continue with the installation.
6. After the Windows OS installation has completed, the system will automatically reboot multiple times for system updates.

Driver Installation

The Supermicro website contains drivers and utilities for your system at the following page:

<https://www.supermicro.com/wdl>.

Some of these drivers and utilities must be installed, such as the chipset driver. After accessing the website, go into the CDR_Images (in the parent directory of the above link) and locate the ISO file for your motherboard. Download this file to a USB flash or media drive. You may also use a utility to extract the ISO file if preferred.

Another option is to go to the Supermicro website at <https://www.supermicro.com>. Find the product page for your motherboard and download the latest drivers and utilities. Insert the flash drive or disk, and the screenshot shown below should appear.

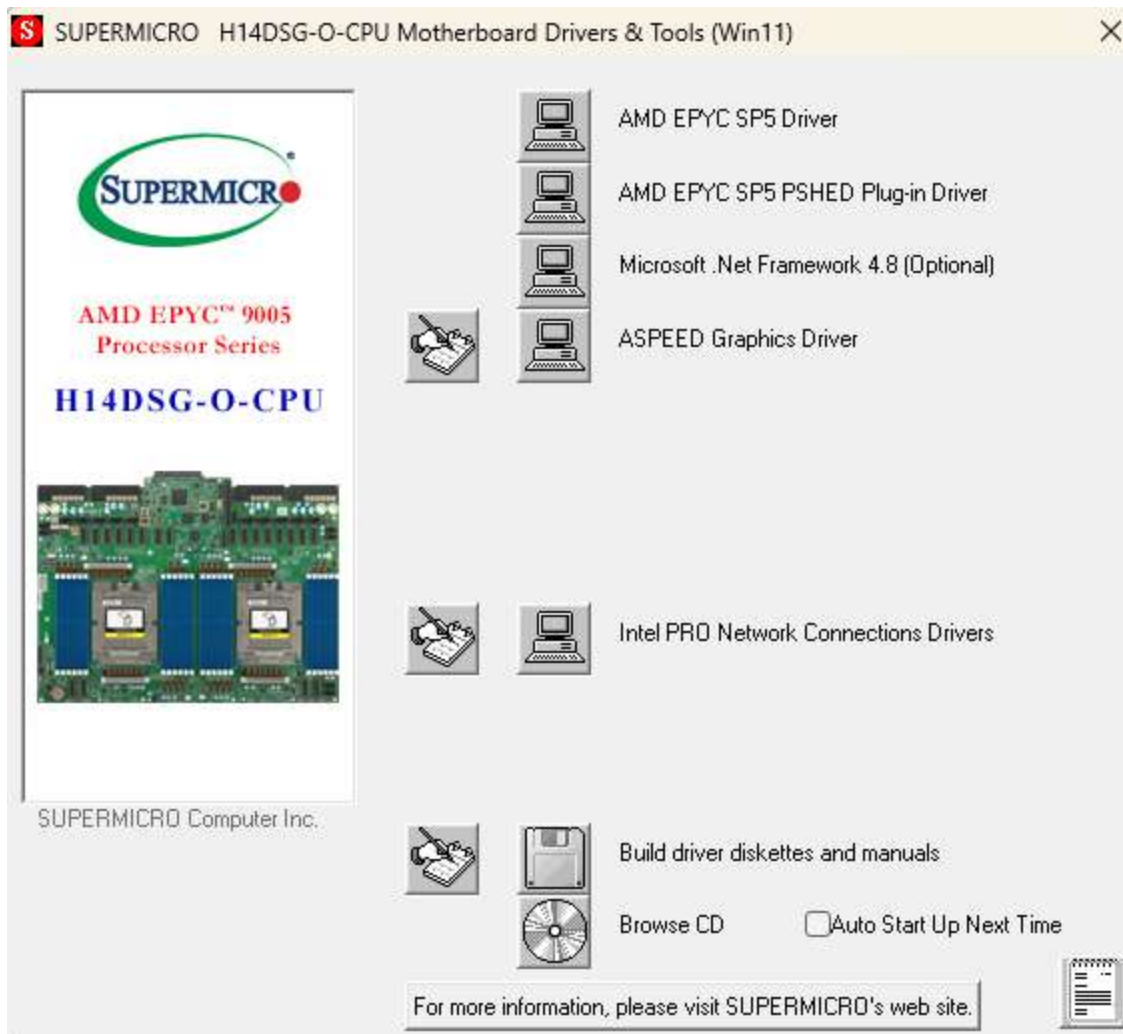

Figure 5-3. Driver & Tools Installation Screen

Note: Click the icons showing a hand writing on paper to view the readme files for each item. Click the computer icons to the right of these items (from top to bottom) one at a time. After installing each item, you must reboot the system before moving on to the next item on the list. The bottom icon with a CD on it allows you to view the entire contents.

5.2 BMC

The H14DSG-O-CPU motherboard provides remote access, monitoring, and management through the baseboard management controller (BMC) and other management controllers distributed among different system modules. There are several BIOS settings that are related to BMC. For general documentation and information on BMC, visit our website at the following page:

<https://www.supermicro.com/en/solutions/management-software/bmc-resources>

BMC ADMIN User Password

For security, each system is assigned a unique default BMC password for the ADMIN user. The password can be found on a sticker on the motherboard and a sticker on the chassis, for Supermicro chassis. The sticker also displays the BMC MAC address. If necessary, the password can be reset using the Supermicro IPMICFG tool.



Figure 5-4. BMC Password Label

Logging into the BMC

Supermicro ships standard products with a unique password for the BMC ADMIN user. This password can be found on a label on the motherboard.

When logging in to the BMC for the first time, use the unique password provided by Supermicro to log in. You can change the unique password to a user name and password of your choice for subsequent logins.

For more information regarding BMC passwords, visit our website at <https://www.supermicro.com/en/support/BMC Unique Password>.

Chapter 6:

Troubleshooting and Support

The following content contains information on common issues and how to resolve them.

6.1 Online Resources	81
6.2 Baseboard Management Controller (BMC)	82
6.3 Troubleshooting Procedures	83
Before Power On	83
No Power	83
No Video	83
System Boot Failure	83
Memory Errors	84
Losing the System's Setup Configuration	84
If the System Becomes Unstable	84
6.4 CMOS Clear	86
6.5 Motherboard Battery	87
6.6 Where to Get Replacement Components	88
6.7 Technical Support Procedures	89
Returning Merchandise for Service	89
6.8 Feedback	91
6.9 TPM Security Module	92

6.1 Online Resources

A great deal of information is available on the Supermicro website. From the top menu of the Supermicro home page at <https://www.supermicro.com>:

- Specifications for servers and other hardware are available by clicking **Products**.
- The **Support** option offers downloads (manuals, BIOS/BMC, drivers, etc.), FAQs, RMA, warranty, and other service extensions.

Direct Links for the AS -5126GS-TNRT/-TNRT2 System

- [AS -5126GS-TNRT](#) and [AS -5126GS-TNRT2](#) specifications page
- [H14DSG-O-CPU](#) motherboard page for links to the Quick Reference Guide, User Manual, validated storage drives, etc.

Direct Links for General Support and Information

- Frequently Asked Questions: <https://www.supermicro.com/FAQ/index.php>
- TPM User Guide: https://www.supermicro.com/manuals/other/AOM-TPM-9670V_9670H_X12_H12.pdf
- Product Resources page for validated memory details: <https://www.supermicro.com/support/resources/mem.cfm>
- Product Matrices page for links to tables summarizing specs for systems, motherboards, power supplies, riser cards, add-on cards, and more: <https://www.supermicro.com/en/support/product-matrices>
- Security Center for recent security notices: https://www.supermicro.com/en/support/security_center
- Supermicro Phone and Addresses: <https://www.supermicro.com/en/about/contact>

6.2 Baseboard Management Controller (BMC)

The AS -5126GS-TNRT/-TNRT2 server supports the Baseboard Management Controller (BMC). BMC is used to provide remote access, monitoring, and management. There are several BIOS settings that are related to BMC.

For general documentation and information on BMC, visit our website at the following page:

<https://www.supermicro.com/en/solutions/management-software/bmc-resources>

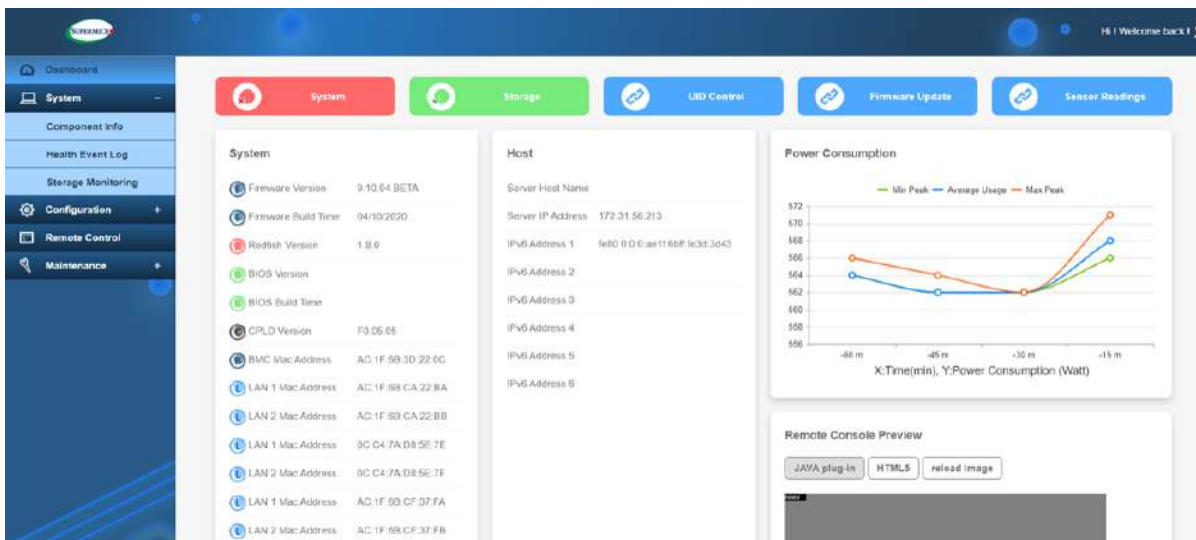

Figure 6-1. BMC Dashboard

6.3 Troubleshooting Procedures

Use the following procedures to troubleshoot your system. If you have followed all of the procedures below and still need assistance, refer to the ["Technical Support Procedures" on page 89](#) section in this chapter. Always disconnect the AC power cord before adding, changing or installing any non hot-swap hardware components. If the below steps do not fix the setup configuration problem, contact your vendor for repairs.

Before Power On

1. Make sure that there are no short circuits between the motherboard and chassis.
2. Disconnect all ribbon/wire cables from the motherboard, including those for the keyboard and mouse.
3. Remove all add-on cards.
4. Install the processor (making sure it is fully seated) and connect the front panel connectors to the motherboard.

No Power

1. Make sure that there are no short circuits between the motherboard and the chassis.
2. The battery on your motherboard may be old. Check to verify that it still supplies approximately 3 VDC. If it does not, replace it with a new one.

No Video

1. If the power is on, but you do not have video, remove all add-on cards and cables.
2. Remove all memory modules and turn on the system (if the alarm is on, check the specs of memory modules, reset the memory, or try a different one).

System Boot Failure

If the system does not display Power-On-Self-Test (POST) or does not respond after the power is turned on, do the following:

1. Remove all components from the motherboard, especially the DIMMs. Power on the system and check if the power-on LED and the BMC Heartbeat LED are on, and system fans are spinning.

2. Turn on the system with only one DIMM installed. If the system boots, check for bad DIMMs or slots by following the Memory Errors Troubleshooting procedure in this chapter.

Memory Errors

When suspecting faulty memory is causing the system issue, check the following:

1. Make sure that the memory modules are compatible with the system and are properly installed. See "[Maintenance and Component Installation](#)" on [page 35](#) for installation instructions. (For memory compatibility, refer to the "Tested Memory List" link on the motherboard's product page to see a list of supported memory.)
2. Check if different speeds of DIMMs have been installed. It is strongly recommended that you use the same RAM type and speed for all DIMMs in the system.
3. Make sure that you are using the correct type of DIMMs recommended by the manufacturer.
4. Check for bad DIMMs or slots by swapping a single module among all memory slots and check the results.

Losing the System's Setup Configuration

1. Make sure that you are using a high-quality power supply. A poor-quality power supply may cause the system to lose the CMOS setup information. Refer to "[Introduction](#)" on [page 11](#) for details on recommended power supplies.
2. The battery on your motherboard may be old. Check to verify that it still supplies approximately 3 VDC. If it does not, replace it with a new one.

If the System Becomes Unstable

If the system becomes unstable during or after OS installation, check the following:

1. Processor/BIOS support: Make sure that your processor is supported and that you have the latest BIOS installed in your system.
2. Memory support: Make sure that the memory modules are supported. Refer to the product page on our website at <https://www.supermicro.com>. Test the modules using memtest86 or a similar utility.

Note: Click on the "Tested Memory List" link on the motherboard's product page to see a list of supported memory.

3. Storage Drive support: Make sure that all storage drives work properly. Replace the failed storage drives with good ones.
4. System cooling: Check the system cooling to make sure that all heatsink fans and processor/system fans, etc., work properly. Check the hardware monitoring settings in the BMC to make sure that the processor and system temperatures are within the normal range. Also, check the front panel Overheat LED and make sure that it is not on.
5. Adequate power supply: Make sure that the power supply provides adequate power to the system. Make sure that all power connectors are connected. Refer to our website for more information on the minimum power requirements.
6. Proper software support: Make sure that the correct drivers are used.

If the system becomes unstable before or during OS installation, check the following:

1. Source of installation: Make sure that the devices used for installation are working properly, including boot devices such as a CD/Media drive.
2. Cable connection: Check to make sure that all cables are connected and working properly.
3. Use the minimum configuration for troubleshooting: Remove all unnecessary components (starting with add-on cards first), and use the minimum configuration (but with the processor and a memory module installed) to identify the trouble areas. Refer to the steps listed above in this section for proper troubleshooting procedures.
4. Identify bad components by isolating them: If necessary, remove a component in question from the chassis, and test it in isolation to make sure that it works properly. Replace a bad component with a good one.
5. Check and change one component at a time instead of changing several items at the same time. This will help isolate and identify the problem.
6. To find out if a component is good, swap this component with a new one to see if the system will work properly. If so, then the old component is bad. You can also install the component in question in another system. If the new system works, the component is good and the old system has problems.

6.4 CMOS Clear

JBT1 on the H14DSG-O-CPU motherboard is used to clear CMOS, which will also clear any passwords. For information on clearing CMOS, refer to ["CMOS Clear" on page 71](#) earlier in this manual.

6.5 Motherboard Battery

For information on removing, disposing of, and replacing the motherboard battery of your system, refer to ["Motherboard Battery Removal and Installation" on page 54](#).

6.6 Where to Get Replacement Components

If you need replacement parts for your AS -5126GS-TNRT/-TNRT2 server, to ensure the highest level of professional service and technical support, purchase exclusively from our Supermicro Authorized Distributors/System Integrators/Resellers. A list can be found on the Supermicro website:

<https://www.supermicro.com>

Under the "Buy" menu, click the "Where to Buy" link.

6.7 Technical Support Procedures

Before contacting Technical Support, take the following steps. Also, note that as a motherboard manufacturer, Supermicro also sells motherboards through its channels, so it is best to first check with your distributor or reseller for troubleshooting services. They should know of any possible problems with the specific system configuration that was sold to you.

1. Refer to "Troubleshooting Procedures" on page 83 or see the FAQs on our website (<https://www.supermicro.com/FAQ/index.php>) before contacting Technical Support.
2. BIOS upgrades can be downloaded from our website (https://www.supermicro.com/support/resources/bios_ipmi.php).
3. If you still cannot resolve the problem, include the following information when contacting Supermicro for technical support:
 - Motherboard model and PCB revision number
 - BIOS release date/version (This can be seen on the initial display when your system first boots up.)
 - System configuration
4. An example of a Technical Support form is on our website at <https://webpr3.supermicro.com/SupportPortal>.
5. Distributors: For immediate assistance, have your account number ready when placing a call to our Technical Support department. For Supermicro contact information, refer to "Contacting Supermicro" on page 10.

Returning Merchandise for Service

A receipt or copy of your invoice marked with the date of purchase is required before any warranty service will be rendered. You can obtain service by calling your vendor for a Returned Merchandise Authorization (RMA) number. When returning the server to the manufacturer, the RMA number should be prominently displayed on the outside of the shipping carton, and the shipping package is mailed prepaid or hand-carried. Shipping and handling charges will be applied for all orders that must be mailed when service is complete.

For faster service, RMA authorizations can be requested online at the following page:

<https://www.supermicro.com/RmaForm>

Whenever possible, repack the server in the original Supermicro carton, using the original packaging material. If these are no longer available, be sure to pack the server securely, using packaging material to surround the server so that it does not shift within the carton and become damaged during shipping.

This warranty only covers normal consumer use and does not cover damages incurred in shipping or from failure due to the alternation, misuse, abuse or improper maintenance of products.

During the warranty period, contact your distributor first for any product problems.

6.8 Feedback

Supernano values your feedback as we strive to improve our customer experience in all facets of our business. Email us at Techwriterteam@supernano.com to provide feedback on our manuals.

6.9 TPM Security Module

This is an SPI-capable TPM 2.0 with Infineon 9672 controller.

The JTPM1 header is used to connect a Trusted Platform Module (TPM). A TPM is a security device that supports encryption and authentication in hard drives. It enables the H14DSG-O-CPU motherboard to deny access if the TPM associated with the hard drive is not installed in the AS -5126GS-TNRT/-TNRT2 server.

For details and installation procedures, refer to the following page:

<https://www.supermicro.com/en/products/accessories/addon/AOM-TPM-9672V.php>

- AOM-TPM-9672V (TCG 2.0)

Chapter 7:

UEFI BIOS

The following content contains information on BIOS configuration with the AS -5126GS-TNRT/-TNRT2 server.

7.1 Introduction	94
7.2 Main Setup	96
7.3 Advanced Setup Configurations	98
7.4 Event Logs	120
7.5 BMC	122
7.6 Security	126
7.7 Boot	128
7.8 Save & Exit	130

7.1 Introduction

This chapter describes the AMIBIOS™ Setup utility for the motherboard. The BIOS is stored on a chip and can be easily upgraded using the UEFI script (flash.nsh), the BMC WebUI, or the SuperServer Automation Assistant (SAA) utility.

Note: Due to periodic changes to the BIOS, some settings may have been added or deleted and might not yet be recorded in this manual. Refer to the Manual Download area of our website for any changes to BIOS that may not be reflected in this manual.

Updating BIOS

It is recommended that you do not upgrade your BIOS if you are not experiencing any problems with your system. Updated BIOS files are located on our website at the following page:

https://www.supermicro.com/support/resources/bios_ipmi.php

Check our BIOS warning message and the information on how to update your BIOS on our website. Select your motherboard model and download the BIOS file to your computer. Also, check the current BIOS revision to make sure that it is newer than your BIOS before downloading.

Important: Do not shut down or reset the system while updating the BIOS to prevent possible system boot failure! Read the motherboard README file carefully before you perform the BIOS update.

Unzip the BIOS file onto a bootable USB device and then boot into the built-in UEFI Shell and type "flash.nsh <BIOS filename><BMC Username><BMC Password>" to start the BIOS update. The flash script will invoke the (EFI) tool automatically to perform the BIOS update, beginning with uploading the BIOS image to BMC. After uploading the firmware, the system will reboot to continue the process. The BMC will take over and continue the BIOS update in the background. The process will take 3–5 minutes.

Starting the Setup Utility

To enter the BIOS Setup utility, press the <Delete> key while the system is booting-up. In most cases, the <Delete> key is used to invoke the BIOS Setup screen. There are a few cases when other hot keys are used, such as <F1>, <F2>, etc. Each main BIOS menu option is described in this manual.

The Main BIOS screen has two main frames. The left frame displays all the options that can be configured. "Grayed-out" options cannot be configured. The right frame displays the key legend. Above the key legend is an area reserved for a text message. When a BIOS submenu or item is selected in the left frame, it is highlighted in white. Often a text message will accompany it. (Note that BIOS has default text messages built in. We retain the option to include, omit, or change any of these text messages.) Settings printed in **Bold** are the default values.

A "▶" indicates a submenu. Highlighting such an item and pressing the <Enter> key open the list of settings within that submenu.

The BIOS Setup utility uses a key-based navigation system called hot keys. Most of these hot keys (<F1>, <F2>, <F3>, <F4>, <F5>, <F6>, <Enter>, <ESC>, the arrow keys, etc.) can be used at any time during the setup navigation process.

7.2 Main Setup

When you first enter the AMI BIOS Setup utility, you enter the Main setup screen. You can always return to the Main setup screen by selecting the Main tab on the top of the screen. The Main BIOS setup screen is shown below.



Figure 7-1. BIOS Main Setup Screen

System Date/System Time

Use the two features to change the system date and time. Highlight **System Date** or **System Time** using the arrow keys. Enter new values using the keyboard. Press the <Tab> key or the arrow keys to move between fields. The date must be entered in MM/DD/YYYY format. The time is entered in HH:MM:SS format.

Note: The time is in the 24-hour format. For example, 5:30 P.M. appears as 17:30:00.

Supermicro H14DSG-O-CPU

BIOS Version

This feature displays the version of the BIOS ROM used in the system.

Build Date

This feature displays the date when the version of the BIOS ROM used in the system was built.

CPLD Version

This feature displays the version of the Complex-Programmable Logical Device (CPLD) used in the system.

Memory Information

Total Memory

This feature displays the total size of memory available in the system.

7.3 Advanced Setup Configurations

Use the arrow keys to select the Advanced submenu and press <Enter> to access the submenu items.

Important: Use caution when changing the Advanced settings. An incorrect value, an improper DRAM frequency, or a wrong BIOS timing setting may cause the system to malfunction. When this occurs, revert the setting to the manufacture default settings.

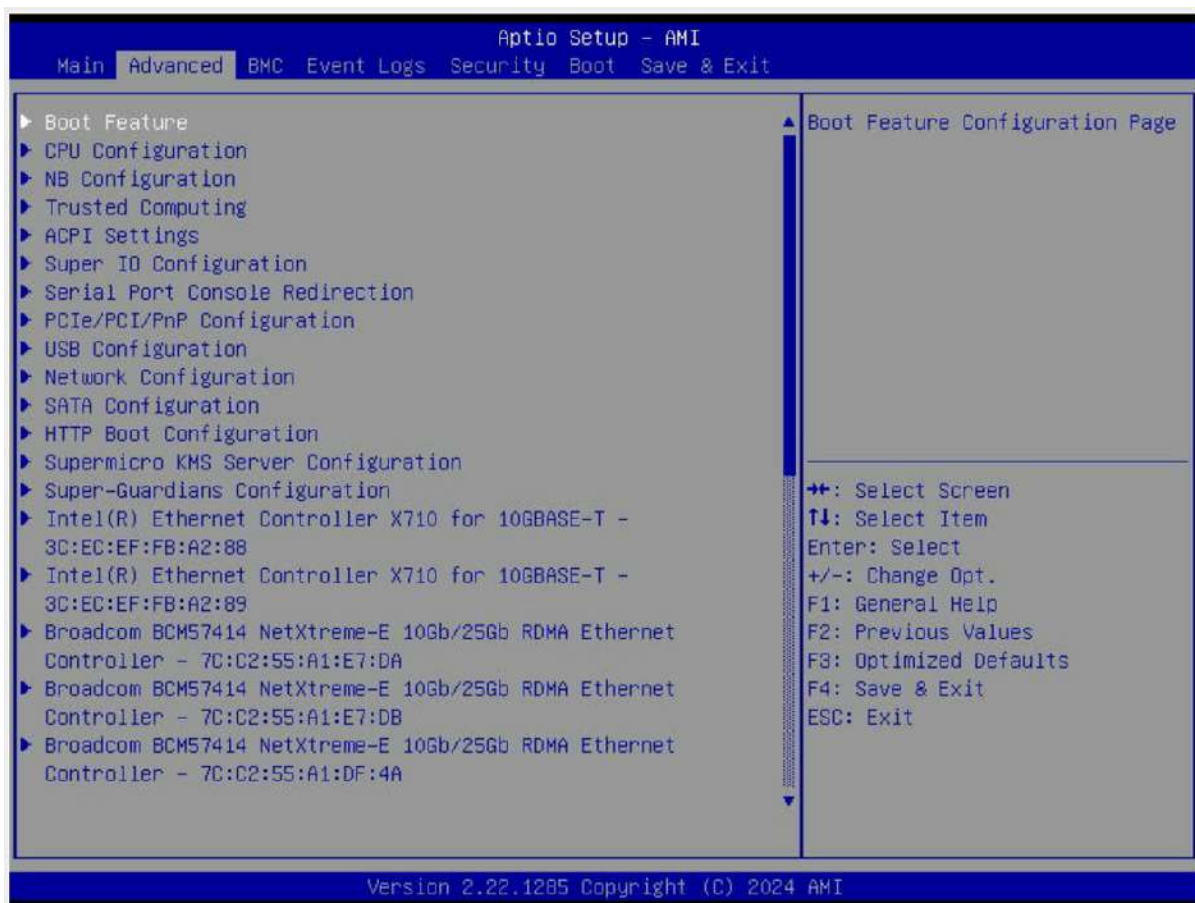

Figure 7-2. Advanced BIOS Screen

Boot Feature Menu

▶ Boot Feature

Quiet Boot

Use this feature to select the screen between displaying the Power-on Self Test (POST) messages or the OEM logo upon bootup. Select Disabled to display the POST messages. Select Enabled to display the OEM logo instead of the normal POST messages. The options

are Disabled and **Enabled**.

Note: BIOS POST messages are always displayed regardless of the setting of this feature.

Option ROM Messages

Use this feature to set the display mode for the Option ROM. Select Keep Current to display the current AddOn ROM display settings. Select Force BIOS to use the Option ROM display mode set by the system BIOS. The options are **Force BIOS** and Keep Current.

Bootup NumLock State

Use this feature to set the Power-on state for the <Numlock> key. The options are **On** and Off.

Wait For "F1" If Error

Select Enabled to force the system to wait until the <F1> key is pressed if an error occurs. The options are **Disabled** and Enabled.

Re-try Boot

If this feature is set to Enabled, the system BIOS will automatically reboot the system from an Extensible Firmware Interface (EFI) boot device after an initial boot failure. The options are **Disabled** and Enabled.

Power Configuration

Watch Dog Function

Select Enabled to allow the Watch Dog timer to reboot the system when it is inactive for more than five minutes. The options are **Disabled** and Enabled.

Watch Dog Action (Available when "Watch Dog Function" is set to Enabled)

Use this feature to configure the Watch Dog Time_out setting. The options are **Reset** and NMI.

Restore on AC Power Loss

Use this feature to set the power state after a power outage. Select Stay Off for the system power to remain off after a power loss. Select Power On for the system power to be turned on after a power loss. Select Last State to allow the system to resume its last power state before a power loss. The options are Stay Off, Power On, and **Last State**.

Power Button Function

This feature controls how the system shuts down when the power button is pressed. Select 4 Seconds Override to power off the system after pressing and holding the power button for four seconds or longer. Select Instant Off to instantly power off the system as soon as you press the power button. The options are **Instant Off** and 4 Seconds Override.

CPU Configuration Menu

Workload Profile

This function allows configuring the BIOS settings to match the selected workload. The options are **Disabled**, HPC, I/O, Virtualization, Telco NFVI, Telco NFVI-FP, and Telco FlexRAN.

SMT Control

This setting is used to disable symmetric multithreading. To re-enable SMT, a power cycle is needed after selecting the Enable option. Select Auto based on BIOS PCD default setting. The options are Disabled, Enabled, and **Auto**.

Core Performance Boost

Disable CPB. The options are Disabled and **Auto**.

Global C-state Control

Controls IO based C-state generation and DF C-states. The options are Disabled, Enabled, and **Auto**.

ACPI CST C2 Latency

Use this setting to enter in microseconds the decimal value. Larger C2 latency values will reduce the number of C2 transitions and reduce C2 residency. Fewer transitions can help when the performance is sensitive to the latency of C2 entry and exit. The default value is **100**.

PPIN Opt-in

Select Unlock/Enabled to use the Protected Processor Inventory Number (PPIN) in the system. The PPIN is a unique number set for tracking a given processor. The options are Disabled, Enabled, and **Auto**.

SMEE

This setting controls Secure Memory Encryption (SME) for the system. The options are Disabled, Enabled, and **Auto**.

Fast Short REP MOVSB (FSRM)

The default is 1, but it can be set to zero for analysis purposes as long as the OS supports it. The options are **Auto**, Enabled, and Disabled.

Enhanced REP MOVSB/STOSB (ERSM)

This setting optimizes CPU string operations. Disabling ERSM (setting it to 0) can be useful for performance analysis if supported by the operating system. The options are Disabled, Enabled, and **Auto**.

AVX512

Enable or disable AVX512. The options are **Auto**, Enabled, and Disabled.

Monitor and MWAIT Disable

This setting controls the availability of the MONITOR, MWAIT, MONITORX, and MWAITX opcodes, which are used for power management and synchronization. The options are Enabled, Disabled, and **Auto**.

L1 Stream HW Prefetcher

This setting is used to enable or disable the L1 Stream Hardware Prefetcher. The options are Disabled, Enabled, and **Auto**.

L2 Stream HW Prefetcher

This setting is used to enable or disable the L2 Stream Hardware Prefetcher. The options are Disabled, Enabled, and **Auto**.

CCD Control

Sets the number of active CCDs. A power cycle is required once this option has been used to remove any CCDs. The options are **Auto**, 2 CCDs, 4 CCDs, 6 CCDs, 8 CCDs, 10 CCDs, 12 CCDs, and 14 CCDs.

Core Control

Sets the number of cores to be used. Once this option has been used to remove any cores, a power cycle is required for future selections to take effect. The options are **Auto**, ONE (1+0), TWO (2+0), THREE (3+0), FOUR (4+0), FIVE (5 +0), SIX (6+0), SEVEN (7+0), TWO (1+1), FOUR (2+2), SIX (3+3), EIGHT (4+4), TEN (5+5), TWELVE (6+6), and FOURTEEN (7+7).

SVM Mode

This setting enables or disables CPU Virtualization. The options are Disabled and **Enabled**.

► CPU1 Information

Changing the designed PCIe port bifurcation.

CPU1 information listed,

CPU1 PCIe Package Group P2 The options are **Auto**, x4x4x4x4, x4x4x8, x8x4x4, x8x8, and x16

CPU1 PCIe Package Group G2

CPU1 PCIe Package Group P3

CPU1 PCIe Package Group G3

CPU1 PCIe Package Group P1

CPU1 PCIe Package Group G1

CPU1 PCIe Package Group P0

CPU1 PCIe Package Group G0

NB Configuration

North Bridge Configuration

IOMMU

Use this setting to enable or disable IOMMU. The options are Disabled, Enabled, and **Auto**.

DMAr Support

Use this setting to enable DMAr system protection during POST (Power-On Self-Test). The options are Disabled, Enabled, and **Auto**.

DMA Protection

Use this setting to enable DMA remap support in the IVRS IVinfo field. The options are **Auto**, Enabled, and Disabled.

DRTM Virtual Device Support

This enables or disables the DRTM ACPI Virtual device. The options are Disabled, Enabled, and **Auto**.

DRTM Memory Reservation

This setting reserves 128 MB of memory below for DRTM security functions. It is required for secured-core servers. The options are Disabled, Enabled, and **Auto**.

ACS Enable

This setting enables Access Control Service (ACS) functionality, which requires AER to be active. The options are Enabled, Disabled, and **Auto**.

TDP Control

Use this setting to set the processor's power consumption (TDP). The options are Manual and **Auto**.

Package Power Limit Control

Use Auto to apply the default power limit (PPT) or Manual to set a custom PPT. The options are Manual and **Auto**.

Determinism Control

Use this setting to configure the level of performance determinism. The options are Manual and **Auto**.

APBDIS

Use this setting to control the APBDIS feature. A value of 0 indicates "not APBDIS" (mission mode). The options are 0, 1, and **Auto**.

Power Profile Selection

Use this setting to select a power profile to optimize performance or efficiency. The options are High Performance Mode, Efficiency Mode, Maximum IO Performance Mode, Balanced Memory Performance Mode, Balanced Core Performance Mode, Balanced Core Memory Performance Mode, and **Auto**.

DF Cstates

This setting controls the power-saving states of the data fabric. The options are Disabled, Enabled, and **Auto**.

Data Link Feature Cap

This setting control the activation of advanced data link features. The options are Enabled, Disabled, and **Auto**.

SEV-SNP Support

This setting controls the activation of Secure Encrypted Virtualization - Secure Nested Paging (SEV-SNP) security features. The options are Disabled, Enabled, and **Auto**.

Periodic Training

This setting controls the method for managing power-saving states. The options are Disabled and **Legacy**.

EQ Bypass To Highest Rate

This setting determines whether the system can bypass equalization steps at lower data rates and directly attempt equalization at the highest supported rate during the link setup process. The options are Disable, Enable, and **Auto**.

CXL Memory Attribute

This setting determines the memory type for CXL devices. The options are **Auto**, Enabled, and Disabled.

Sync Header Bypass

This setting controls the inclusion of synchronization headers in data transmissions. The options are **Auto**, Enabled, and Disabled.

► xGMI Configuration

xGMI Force Link Width Control (available when xGMI Link Width Control is set to Manual)

This setting forces a specific link width for the xGMI interface, overriding automatic settings for manual control. The options are **Auto**, Unforce, and Force.

xGMI Link Max Speed

This setting controls the maximum speed of the xGMI link. The options are 20 Gbps, 25 Gbps, 32 Gbps, and **Auto**.

► Memory Configuration

Memory Target Speed

Use this setting to specify the memory target speed in MT/s. The options are **Auto**, DDR3600, DDR4000, DDR4400, DDR4800, and DDR5200.

Memory Interleaving

This setting controls fabric level memory interleaving. Note that the channel, die and socket have requirements on memory populations and it will be ignored if the memory doesn't support the selected option. The options are Disabled, Enabled, and **Auto**.

Chipselect Interleaving

This setting allows memory blocks to be interleaved across the DRAM chip selects for node 0, which can enhance memory performance. The options are Disabled and **Auto**.

BankSwapMode

This setting determines the operation of memory banks in relation to CPU usage. The options are **Auto**, Disabled, and Swap CPU.

Power Down Enable

Use this setting to enable or disable DDR power down mode. The options are Disabled, Enabled, and **Auto**.

DRAM Scrub Time

This setting specifies the frequency of memory scrubbing, which helps maintain data integrity by refreshing memory contents. The options are Disabled, 1 hour, 4 hours, 6 hours, 8 hours, 12 hours, 16 hours, **24 hours**, and 48 hours.

TSME

This setting controls the Transparent Secure Memory Encryption feature. The options are **Auto**, Enabled, and Disabled.

Enhanced PPR

Use this setting to enable a full memory test during system setup. While this thorough testing can enhance system stability, it will also increase the overall boot time. The options are **Disabled** and Enabled.

► CPU1 Memory Information

View memory information for CPU1.

► CPU2 Memory Information

View memory information for CPU2.

Trusted Computing Menu

Configuration

Security Device Support

If this feature and the TPM jumper on the motherboard are both set to Enabled, onboard security devices will be enabled for TPM (Trusted Platform Module) support to enhance data integrity and network security. Please reboot the system for a change on this setting to take effect. The options are Disabled and **Enabled**.

When "Security Device Support" is set to Enabled and a TPM 2.0 device is detected by the BIOS, the following information is displayed.

- Active PCR banks
- Available PCR banks

Note: The following features are available when a TPM 2.0 device is detected by the BIOS.

ACPI Settings Menu

► ACPI Settings

High Precision Event Timer

Enable the High Precision Event Timer. The default is **Enabled**.

PCI AER Support

Use this setting to enable ACPI OS to natively manage PCI advanced error reporting. The default is **Disabled**.

NUMA Nodes per Socket

A NUMA architecture divides hardware resources, including processors, memory, and I/O buses, into groups, called NUMA nodes. This setting specifies the number of desired NUMA nodes per sockets. Selecting Zero will attempt to interleave the two sockets together. **Auto** is equivalent to NPS1.

ACPI SRAT L3 Cache As NUMA Domain

This setting determines how the system's NUMA (Non-Uniform Memory Access) domains are defined in relation to the L3 cache. The options are Disabled, Enabled, and **Auto**.

Super IO Configuration Menu

► Super IO Configuration

Note: This submenu is available when your system supports this feature.

The following information is displayed.

- Super IO Chip

Select for Serial Port 1 or Serial Port 2.

Serial Port 1 Configuration Menu

Serial Port 1 Configuration

Serial Port 1

Select Enabled to enable serial port 1. The options are Disabled and **Enabled**.

Device Settings (Available when "Serial Port 1" above is set to Enabled)

This feature displays the base I/O port address and the Interrupt Request address of serial port 1.

Change Settings (Available when "Serial Port 1" above is set to Enabled)

Use this feature to specify the base I/O port address and the Interrupt Request address of serial port 1. Select Auto for the BIOS to automatically assign the base I/O and IRQ address to serial port 1. The options are **Auto**, (IO=3F8h; IRQ=4;), (IO=3F8h; IRQ=3,4,5,6,7,9,10,11,12;), (IO=2F8h; IRQ=3,4,5,6,7,9,10,11,12;), (IO=3E8h; IRQ=3,4,5,6,7,9,10,11,12;), and (IO=2E8h; IRQ=3,4,5,6,7,9,10,11,12;).

Serial Port 2 Configuration Menu

Serial Port 2 Configuration

Serial Port 2/SOL ("Serial Port 2" or "SOL" based on your system support)

Select Enabled to enable serial port 2 (or SOL). The options are Disabled and **Enabled**.

Device Settings (Available when "Serial Port 2/SOL" above is set to Enabled)

This feature displays the base I/O port address and the Interrupt Request address of serial port 2 (or SOL).

Change Settings (Available when "Serial Port 2/SOL" above is set to Enabled)

Use this feature to specify the base I/O port address and the Interrupt Request address of serial port 2 (or SOL). Select Auto for the BIOS to automatically assign the base I/O and IRQ address to serial port 2 (or SOL). The options are **Auto**, (IO=2F8h; IRQ=3;), (IO=3F8h; IRQ=3,4,5,6,7,9,10,11,12;), (IO=2F8h; IRQ=3,4,5,6,7,9,10,11,12;), (IO=3E8h; IRQ=3,4,5,6,7,9,10,11,12;), and (IO=2E8h; IRQ=3,4,5,6,7,9,10,11,12;).

Serial Port 2 Attribute (Available for Serial Port 2 only)

Select SOL to use serial port 2 as a Serial Over LAN (SOL) port for console redirection. The options are **SOL** and COM.

Serial Port Console Redirection Menu

COM1 (Available when your system supports the serial port of COM1)

Console Redirection

Select Enabled to enable COM port 1 for Console Redirection, which allows a client machine to be connected to a host machine at a remote site for networking. The options are **Disabled** and Enabled.

Note: This feature will be set to Enabled if there is no BMC support.

► Console Redirection Settings

Note: This submenu is available when "Console Redirection" for COM1 or SOL/COM2 is set to Enabled.

Out-of-Band Mgmt Port

The feature selects a serial port in a client server to be used by the Microsoft Windows Emergency Management Services (EMS) to communicate with a remote host server. The options are **COM1** and SOL/COM2. Please note that the option of SOL/COM2 indicates a shared serial port. SOL is available with BMC support.

Terminal Type

Use this feature to select the target terminal emulation type for Console Redirection. Select VT100 to use the ASCII Character set. Select VT100+ to add color and function key support. Select ANSI to use the Extended ASCII Character Set. Select VT-UTF8 to use UTF8 encoding to map Unicode characters into one or more bytes. The options are VT100, **VT100+**, VT-UTF8, and ANSI.

Bits Per Second EMS

This feature sets the transmission speed for a serial port used in Console Redirection. Make sure that the same speed is used in the host computer and the client computer. A lower transmission speed may be required for long and busy lines. The options are 9600, 19200, 57600, and **115200** (bits per second).

Flow Control EMS

Use this feature to set the flow control for Console Redirection to prevent data loss caused by buffer overflow. Send a "Stop" signal to stop sending data when the receiving buffer is full. Send a "Start" signal to start sending data when the receiving buffer is empty. The options are **None**, Hardware RTS/CTS, and Software Xon/Xoff.

The following information is displayed.

- **Data Bits EMS**
- **Parity EMS**
- **Stop Bits EMS**

► Legacy Console Redirection Settings

Legacy Serial Redirection Port

Select a COM port to display redirection of legacy OS and legacy OPRM messages. The options are **COM1** and SOL/COM2.

Resolution

On legacy OS, the number of rows and columns supported redirection. The options are 80x24 and **80x25**.

Redirection After BIOS Post

When bootloader is selected, then legacy console redirection is disabled before booting to legacy OS. When always is select, then legacy console redirection is enabled for legacy OS. The options are **Always Enable** and BootLoader.

Serial Port for Out-of-Band Management/Windows Emergency Management Services (EMS)

The feature allows you to configure Console Redirection settings to support Out-of-Band Serial Port management.

Console Redirection EMS

Select Enabled to use the SOL port for Console Redirection. The options are **Disabled** and Enabled.

PCIe/PCI/PnP Configuration Menu

Above 4G Decoding

This setting enables 64-bit PCI device access to memory beyond 4 GB for improved memory utilization and performance. The options are Disabled and **Enabled**.

Re-Size BAR Support

This setting enables or disables the Re-Size Base Address Register feature for compatible PCIe devices, which allows the system to allocate more memory to the device. The options are Disabled and **Enabled**.

SR-IOV Support

This setting enables or disables Single Root I/O Virtualization support for the system's PCIe devices. The options are Disabled and **Enabled**.

BME DMA Mitigation

This setting enables or disables Bus Mastering Error (BME) Direct Memory Access (DMA) mitigation for protection during the pre-boot process. The options are **Disabled** and Enabled.

ASPM Support

Configure the Active State Power Management (ASPM) level for PCIe links to optimize power consumption and performance. The options are **Disabled**, Auto, and Force L1.

PCIe ARI Support

This setting enables alternative routing-ID interpretation. The options are **Enabled** and Disabled.

PCIe ARI Enumeration

This setting controls the forwarding of Alternate Routing-ID Interpretation (ARI) information for each downstream port, which is essential for device identification in PCIe systems. The options are Disabled, Enabled, and **Auto**.

Relaxed Ordering

This setting determines whether PCI Express devices are permitted to bypass strict transaction ordering, which can lead to potential performance improvements. The options are Disabled and **Enabled**.

Clock Spread Spectrum

This setting allows the BIOS to monitor and reduce the level of Electromagnetic Interference (EMI) generated by system components. The options are **Disabled** and Enabled.

No Snoop

This setting configures the No Snoop option for PCI Express devices, determining whether memory accesses bypass the cache. The options are Disabled and **Enabled**.

VGA Priority

This setting allows you to choose the primary video output source for the system. The options are **Onboard** and External.

PCIe Ten Bit Tag Support

This setting enables the use of ten-bit tags for PCIe devices, which can improve data handling and management. The options are Disabled, Enabled, and **Auto**.

NVMe Firmware Source

This setting determines the source of firmware for NVMe devices, allowing you to select between native support or vendor-specific firmware. The options are **Vendor Defined Firmware** and AMI Native Support.

PCI Devices Option ROM Setting

Onboard Video Option ROM

This setting selects the type of firmware to be loaded for onboard video. The options are Disabled and **EFI**.

M.2-C1 OPROM

This setting enables or disables the Option ROM for the M.2-C1 slot. The options are Disabled and **EFI**.

AOC-AG-i4 LAN1 OPROM

This setting enables or disables the onboard LAN OPROM option. The options are Disabled and **EFI**.

USB Configuration

USB Configuration

USB Module Version

USB Controllers: 2 XHCIs

USB Devices: 1 Keyboard, 1 Mouse, 3 Hubs

XHCI Hand-off

This setting provides a workaround for operating systems that do not support XHCI hand-off. The XHCI ownership change must be claimed by the XHCI driver. The options are **Enabled** and Disabled.

Network Configuration Menu

Network Stack

This setting enables the UEFI network stack. The options are Disabled and **Enabled**.

IPv4 PXE Support

This setting enables IPv4 PXE boot support. The options are Disabled and **Enabled**.

IPv6 HTTP Support

This setting enables IPv6 HTTP boot support. The options are Disabled and **Enabled**.

PXE Boot Wait Time

This sets the wait time, in seconds, to press the ESC key to abort the PXE boot. Use either +/- or numeric keys to set the value. The default value is **0**.

Media Detect Count

This sets the number of times the presence of media will be checked. Use either +/- or numeric keys to set the value. The default value is **1**.

► IPv4 Network Configuration

Configured

This setting indicates whether the network address configured successfully. The options are Disabled and **Enabled**.

Enable DHCP

The options are **Disabled** and Enabled.

Local IP Address

Enter and IP address.

Local NetMask

Enter the Netmask address.

Local Gateway

Enter the Gateway IP address.

Local DNS Servers

Enter the DNS servers IP addresses.

Save Changes and Exit

The options are **Yes** and no.

► IPv6 Network Configuration

Set IPv6 Network parameters.

► Enter Configuration Menu

Interface Name

Interface Type

MAC address

Host addresses

Route Table

Gateway addresses

DNS addresses

Interface ID

DAD Transmit Count

The number of consecutive Neighbor Solicitation messages sent while performing Duplicate Address Detection on a tentative address. A value of zero indicates that Duplicate Address Detection is not performed. The default value is **1**.

► Advanced Configuration

Note: This submenu is available when "Policy" is set to Manual.

New IPv6 address

Use this to set a new manual IP address. It can only be configured under manual policy.

New Gateway addresses

Use this to set new gateway addresses. Gateway IP addresses can only be configured under manual policy.

New DNS addresses

Use this to set new DNS addresses. DNS addresses can only be configured under manual policy.

Commit Changes and Exit

Discard Changes and Exit

Policy

Use this feature to select how the policy is to be configured. The options are **Automatic** and **Manual**.

Save Changes and Exit

The options are **Yes** and **No**.

► Advanced Configuration

Note: This submenu is available when "Policy" is set to **Manual**.

New IPv6 address

Use this to set a new manual IP address. It can only be configured under manual policy.

New Gateway addresses

Use this to set new gateway addresses. Gateway IP addresses can only be configured under manual policy.

New DNS addresses

Use this to set new DNS addresses. DNS addresses can only be configured under manual policy.

Commit Changes and Exit

Discard Changes and Exit

Save Changes and Exit

The options are **Yes** and **No**.

SATA Configuration Menu

SATA Configuration

SATA Enable

Disable or enable the OnChip SATA controller. The options are **Disabled**, **Enabled**, or **Auto**.

SATA Information

Provides SATA devices information.

HTTP Boot Configuration Menu

HTTP Boot Configuration

HTTP Boot Policy

Use this feature to set the HTTP boot policy. The options are Apply to all LANs, **Apply to each LAN**, and Boot Priority #1 instantly.

HTTPS Boot Checks Hostname

Important: Disabling "HTTPS Boot Checks Hostname" is a violation of RFC 6125 and may expose you to Man-in-the-Middle Attacks. Supermicro is not responsible for any and all security risks incurred by you disabling this feature.

This setting determines whether HTTPS Boot verifies that the hostname in the server's TLS certificate matches the hostname of the remote server. The options are **Enabled** and Disabled (WARNING: Security Risk!!).

Priority of HTTP Boot

Instance of Priority 1: (Available when your motherboard supports this feature)

This feature sets the rank target port. The default setting is 1.

Select IPv4 or IPv6

This feature specifies which connection the target LAN port should boot from. The options are **IPv4** and IPv6.

Boot Description

Use this feature to enter a boot description, which cannot be longer than 75 characters. Please be sure to enter a boot description; otherwise, the boot option for the URI cannot be created.

Boot URI

Enter a Boot Uniform Research Identifier (URI) with 128 characters or shorter. This Boot URI determines how IPv4 Boot Option and IPv6 Boot Option will be created. This feature is only supported on Dual or EFI Boot Mode.

Supermicro KMS Server Configuration Menu

► Supermicro KMS Server Configuration

Note: Be sure to configure all the features in the submenu of Supermicro KMS Server Configuration and the feature of "KMS Security Policy" in the submenu of Super-Guardians Configuration so that your system can communicate with the KMS server.

Supermicro KMS Server IP address

Use this feature to set the Supermicro Key Management Service (KMS) server IPv4 address in dotted-decimal notation.

Second Supermicro KMS Server IP address

Use this feature to set the second Supermicro KMS server IPv4 address in dotted-decimal notation.

Supermicro KMS TCP Port number

Use this feature to set the TCP port number used in Supermicro KMS Server. The valid range is 100–9999. The default setting is **5696**. Do not change the default setting unless a different TCP port number has been specified and used in the Supermicro KMS Server.

KMS Time Out

Use this feature to enter the KMS server connecting time-out (in seconds). The default setting is **5** (seconds).

TimeZone

Use this feature to set the correct time zone. The default setting is **0** (not specified).

Client UserName

Press <Enter> to set the client identity (UserName). The username can be between 0 and 63 characters in length.

Client Password

Press <Enter> to set the client identity (Password). The password can be between 0 and 31 characters in length.

► CA Certificate

This setting provides options for managing the Certificate Authority (CA) certificate. The options are **Update**, Delete, and Export.

► Client Certificate

This setting provides options for managing the client certificate. The options are **Update**, Delete, and Export.

► Client Private Key

Use the three features to enroll factory defaults or load the KMS Transport Layer Security (TLS) certificates, which are generated by the KMS Server, from the file stored in the USB flash drive as shown below.

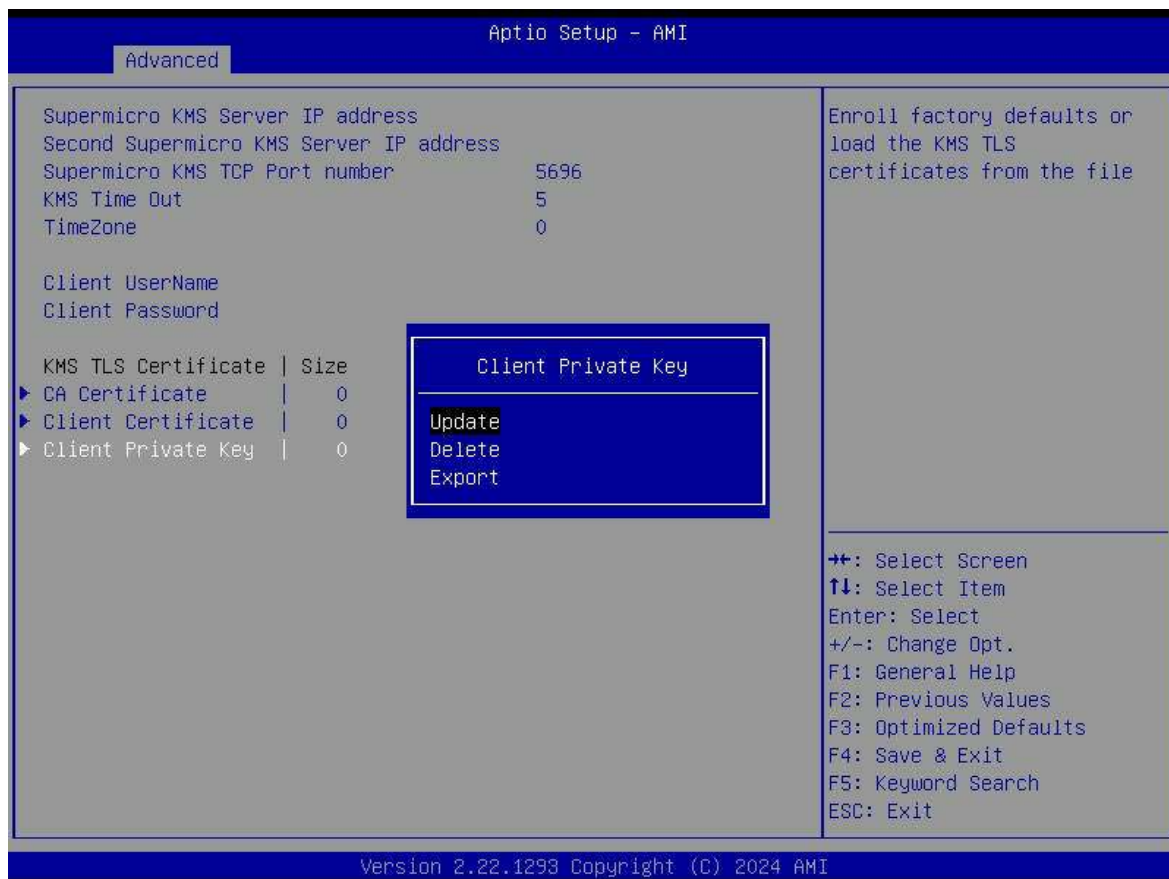

Private Key Password (Available when "Client Private Key" above has been set)

Use this feature to change the password for the client private key.

Super-Guardians Configuration Menu

▶ Super-Guardians Configuration

Super-Guardians Protection Policy

Use this feature to enable the Super-Guardians Protection Policy. The options are **Storage**, **System**, and **System and Storage**. Set this feature to **Storage** to protect and have secure access to Trusted Computing Group (TCG) NVMe devices with the Authentication-Key (AK). Set this feature to **System** to protect and have secure access to your system/motherboard with the AK. Set this feature to **System and Storage** to protect and have secure access to your system/motherboard/storage devices with the AK.

KMS Security Policy (Available when "TPM Security Policy" and "USB Security Policy" are set to Disabled)

Set this feature to **Enabled** to enable the KMS Security Policy. When this feature has not previously been set to **Enabled**, the options are **Disabled** and **Enabled**. Changes take effect after you save settings and reboot the system.

When this feature has previously been set to Enabled, the options are **Enabled**, Reset, and Key Rotation. Set this feature to Key Rotation to obtain an existing AK from the KMS server and create a new AK. To disable the KMS Security Policy, set this feature to Reset. When this feature is set to Reset, the system and TCG NVMe devices chosen in "Super-Guardians Protection Policy" will be in the unprotected mode.

Notes:

- Be sure that the KMS server is ready before configuring this feature.
- Use the professional KMS server solutions (e.g., Thales Server) or the Supermicro PyKMIP Software Package to establish the KMS server.

KMS Server Retry Count (Available when "TPM Security Policy" and "USB Security Policy" are set to Disabled)

Use this feature to specify how many times the system will attempt reconnecting to the KMS server. The valid range is 0–10. Press the <+> or <-> key on your keyboard to change the value. The default setting is 5. If the value is 0, the system will retry infinitely.

TPM Security Policy (Available when "KMS Security Policy" and "USB Security Policy" are set to Disabled)

Set this feature to Enabled to enable the TPM Security Policy. When this feature has not previously been set to Enabled, the options are **Disabled** and Enabled. Changes take effect after you save settings and reboot the system.

When this feature has previously been set to Enabled, the options are **Enabled** and Reset. To disable the TPM Security Policy, set this feature to Reset. When this feature is set to reset, the system and TCG NVMe devices chosen in "Super-Guardians Protection Policy" will be in the unprotected mode.

Note: Be sure to install a TPM 2.0 device to your system before configuring this feature.

Load Authentication-Key (Available when "KMS Security Policy," "TPM Security Policy," and "USB Security Policy" are set to Disabled)

The options are **Disabled** and Enabled. Set this feature to Enabled. Changes take effect after you save settings and reboot the system. While booting, the BIOS will automatically load the Authentication-Key (filename: TPMAuth.bin) from the USB flash drive. Afterwards, the default setting will be set to Disabled by the BIOS.

Notes:

- Be sure to connect a USB flash drive with the Authentication-Key (filename: TPMAuth.bin) to your system before the system reboot.
- Be sure to save the Authentication-Key (filename: TPMAuth.bin) to the USB flash drive and have a backup. Please load the Authentication-Key (filename: TPMAuth.bin) after installing a TPM device. Otherwise, the TPM function can not work properly.

USB Security Policy (Available when "KMS Security Policy" and "TPM Security Policy" are set to Disabled)

Use this feature to enable the USB Security Policy. The options are **Disabled** and Enabled. Set this feature to Enabled. Changes take effect after you save settings and reboot the system. Connect a USB flash drive to your system before the system reboot. While booting, the BIOS will automatically create the USB Authentication-Key (filename: USBAuth.bin) and save it to the USB flash drive.

When this feature has been previously set to Enabled, the options are **Enabled** and Reset. To disable the USB Security Policy, set this feature to Reset. When this feature is set to Reset, the system and TCG NVMe devices chosen in "Super-Guardians Protection Policy" will be in the unprotected mode.

Note: Be sure to connect a USB flash drive to your system before configuring this feature. Save the USB Authentication-Key (filename: USBAuth.bin) to the USB flash drive and keep a backup.

TLS Authenticate Configuration Menu

► Server CA Configuration

This feature allows you to configure the client certificate that is to be used by the server.

► Enroll Certification

This feature allows you to enroll the certificate in the system.

Certification GUID

Press <Enter> and input the certification Global Unique Identifier (GUID).

► Commit Changes and Exit

Use this feature to save all changes and exit TLS settings.

► Discard Changes and Exit

Use this feature to discard all changes and exit TLS settings.

► Delete Certification

This feature is used to remove the selected TLS certificates that are no longer needed or valid.

► Client Certification Configuration

Use this feature to manage the TLS certificates used to authenticate remote clients connecting to your system. Add, view, or delete client certificates as needed.

Driver Health Menu

► Driver Health

This feature displays the health information of the drivers installed in your system, including LAN controllers, as detected by the BIOS. Select one and press <Enter> to see the details.

Note: This section is provided for reference only, for the driver health status will differ depending on the drivers installed in your system. It's also based on your system configuration and the environment that your system is operating in.

7.4 Event Logs

Use this menu to configure Event Logs settings.

Note: After you've made any changes in this section, please be sure to reboot the system for the changes to take effect.

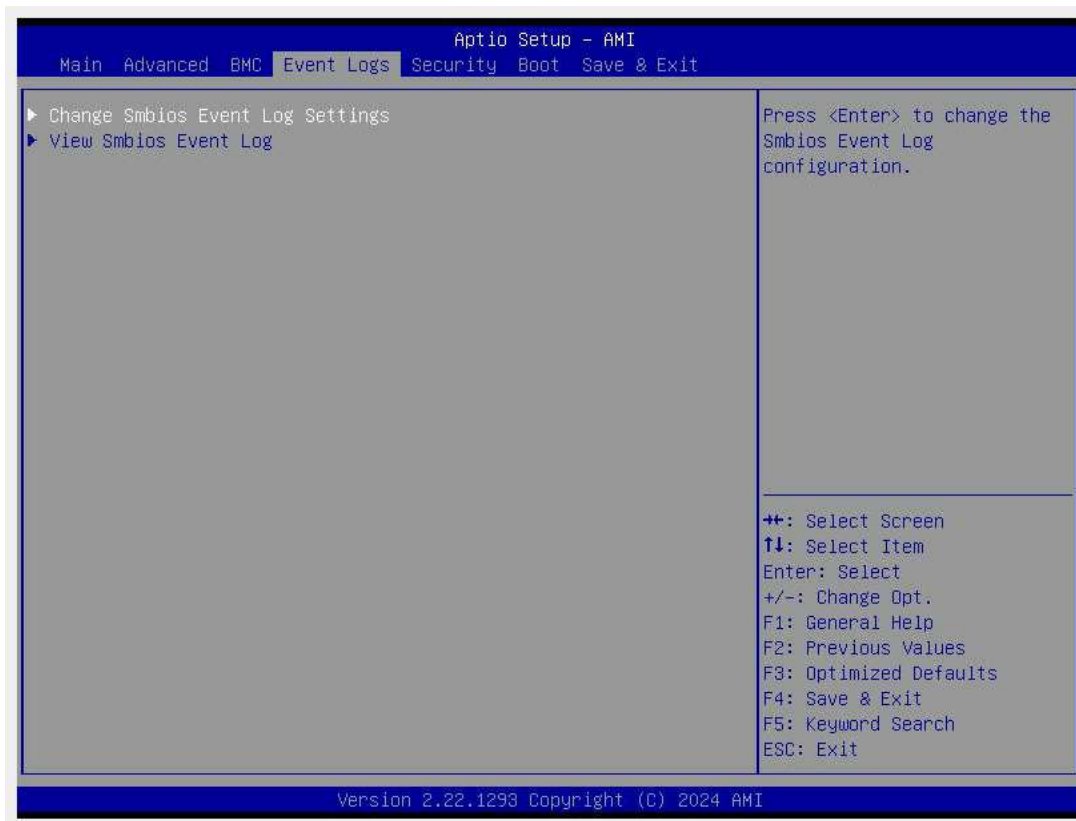

Figure 7-3. Event Logs Screen

► Change SMBIOS Event Log Settings

Note: Please reboot the system for the changes in this section to take effect.

Enabling / Disabling Options

SMBIOS Event Log

Change this to enable or disable all features of smbios event logging during boot. The options are Disabled and **Enabled**.

Erasing Settings

Erase Event Log

Select No to keep the event log without erasing it upon next system bootup. Select Yes, Next Reset to erase the event log upon next system reboot. The options are **No**, Yes, Next Reset, and Yes, Every Reset

When Log Is Full

Select Erase Immediately to immediately erase all errors in the SMBIOS event log when the event log is full. Select Do Nothing for the system to do nothing when the SMBIOS event log is full. The options are **Do Nothing** and Erase Immediately.

SMBIOS Event Log Standard Settings

Log System Boot Event

Choose the option to enable or disable logging of system boot events. The options are Enabled and **Disabled**.

MECI (Multiple Event Count Increment)

Enter the increment value for the multiple event counter. Enter a number between 1 to 255. The default setting is **1**.

METW (Multiple Event Count Time Window)

This feature is used to determine how long (in minutes) should the multiple event counter wait before generating a new event log. Enter a number between 0 to 99. The default setting is **60**.

► [View SMBIOS Event Log](#)

This feature allows the user to view the event in the system event log. Select this item and press <Enter> to view the status of an event in the log. The following categories are displayed:

Date/Time/Error Code/Severity

7.5 BMC

Use this menu to configure Baseboard Management Console (BMC) settings.



Figure 7-4. BMC Screen

BMC Firmware Revision

This feature indicates the BMC firmware revision used in your system.

BMC STATUS

This feature indicates the status of the BMC firmware installed in your system.

System Event Log Menu

Enabling / Disabling Options

SEL Components

Select Enabled for all system event logging at bootup. The options include Disabled and Enabled.

Erasing Settings

Erase SEL

Select Yes, On next reset to erase all system event logs upon next system reboot. Select Yes, On every reset to erase all system event logs upon each system reboot. Select No to keep all system event logs after each system reboot. The options include **No**, Yes, On next reset, and Yes, On every reset.

When SEL is Full

This feature allows you to decide what the BIOS should do when the system event log is full. Select Erase Immediately to erase all events in the log when the system event log is full. The options include **Do Nothing** and Erase Immediately.

BMC Network Configuration Menu

Update BMC LAN Configuration

Select Yes for the BIOS to implement all IP/MAC address changes upon next system boot. The options are **No** and Yes.

Configure IPv4 Support

BMC LAN Selection

This feature displays the type of the BMC LAN.

BMC Network Link Status:

This feature displays the status of the BMC network link for this system.

Configuration Address Source (Available when "Update BMC LAN Configuration" is set to Yes)

Use this feature to select the source of the IPv4 connection. If Static is selected, you will need to know the IP address of IPv4 connection and enter it to the system manually in the field. If DHCP is selected, the BIOS will search for a Dynamic Host Configuration Protocol (DHCP) server in the network that is attached to and request the next available IP address for this computer. The options are Static and **DHCP**.

Station IP Address

This feature displays the Station IP address in decimal and in dotted quad form (i.e., 172.29.176.131). It is available for configuration when "Configuration Address Source" above is set to Static.

Subnet Mask

This feature displays the sub-network that this computer belongs to. It is available for configuration when "Configuration Address Source" above is set to Static.

Station MAC Address

This feature displays the Station MAC address for this computer. Mac addresses are six two-digit hexadecimal numbers.

Gateway IP Address

This feature displays the Gateway IP address for this computer. This should be in decimal and in dotted quad form (i.e., 172.29.0.1). It is available for configuration when "Configuration Address Source" above is set to Static.

Configure IPv6 Support

IPv6 Address Status

This feature displays the status of the IPv6 address.

IPv6 Support (Available when "Update BMC LAN Configuration" is set to Yes)

Use this feature to enable IPv6 support. The options are **Enabled** and Disabled.

Configuration Address Source (Available when "IPv6 Support" is set to Enabled)

Use this feature to select the source of the IPv6 connection. If Static Configuration is selected, you will need to know the IP address of IPv6 connection and enter it to the system manually in the field. If the other two options are selected, the BIOS will search for a DHCP server in the network that is attached to and request the next available IP address for this computer. The options are Static Configuration, **DHCPv6 Stateless**, and DHCPv6 Stateful.

IPv6 Address ("Static," "DHCPv6 Stateless," or "DHCPv6 Stateful," depending on the option you selected for "Configuration Address Source" above)

This feature displays the station IPv6 address. It is available for configuration when "Configuration Address Source" above is set to Static Configuration.

Prefix Length

This feature displays the prefix length. It is available for configuration when "Configuration Address Source" above is set to Static Configuration.

Gateway IP

This feature displays the IPv6 gateway IP address. It is available for configuration when "Configuration Address Source" above is set to Static Configuration.

Advanced Settings (Available when "Configuration Address Source" is set to DHCPv6 Stateless)

Use this feature to set the DNS server IP. The default setting allows your system to obtain the DNS server IP automatically. The options are **Auto obtain DNS server IP** and **Manually obtain DNS server IP**.

Preferred DNS server IP (Available when "Advanced Settings" above is set to Manually obtain DNS server IP)

This feature displays the preferred DNS server IP. It can be configured via Redfish.

Alternative DNS server IP (Available when "Advanced Settings" above is set to Manually obtain DNS server IP)

This feature displays the alternative DNS server IP. It can be configured via Redfish.

Configure VLAN Support

VLAN Support (Available when "Update BMC LAN Configuration" is set to Yes)

Use this feature to enable the virtual LAN (VLAN) support. The options are **Enabled** and **Disabled**.

7.6 Security

This menu allows you to configure the following security settings for the system.

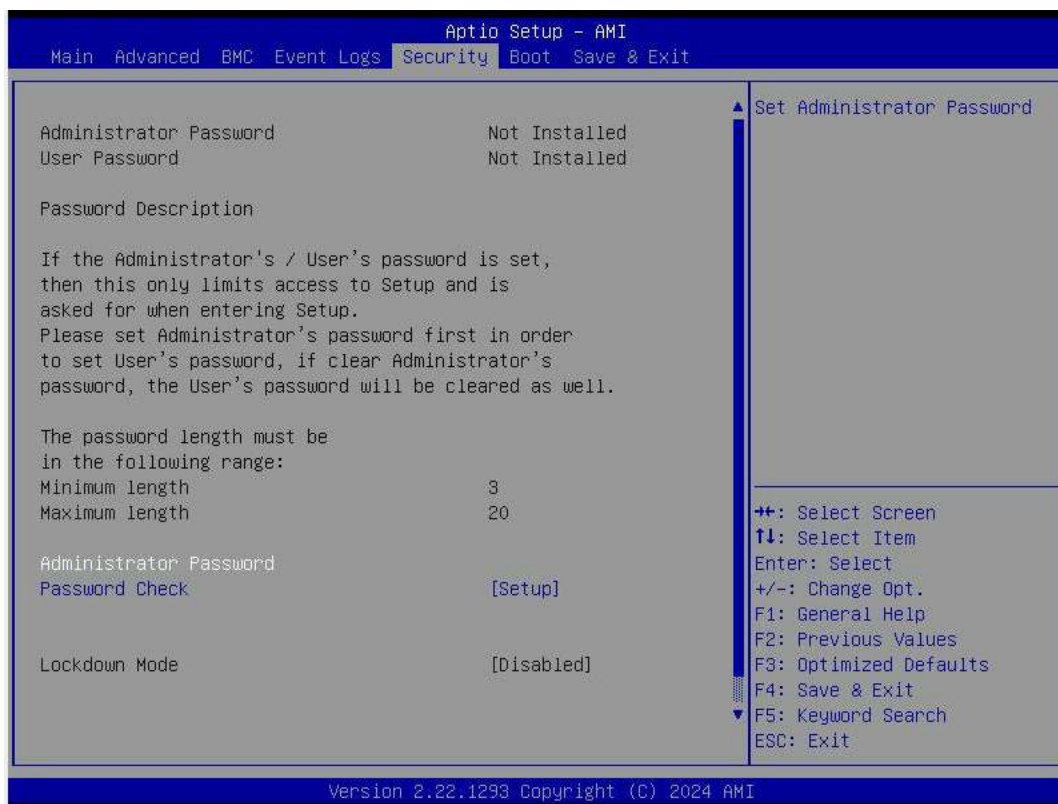

Figure 7-5. Security Screen

Administrator Password

This feature indicates if an administrator password has been installed. Use this feature to set the administrator password, which is required to enter the BIOS Setup utility. The length of the password can be between three and 20 characters long.

Password Check

Select Setup for the system to check for a password at Setup. Select Always for the system to check for a password at bootup and upon entering the BIOS Setup utility. The options are **Setup** and **Always**.

► Supermicro Security Erase Configuration

Use this submenu to configure the Supermicro-proprietary Security Erase settings. When this submenu is selected, the following information is displayed. Please note that the order of the following information may differ based on the storage devices being detected.

- **HDD Name:** This feature displays the model name of the storage device that is detected by the BIOS.
- **HDD Serial Number:** This feature displays the serial number of the storage device that is detected by the BIOS.
- **Security Mode:** This feature displays the security mode of the storage device that is detected by the BIOS.
- **Estimated Time:** This feature displays the estimate time needed to perform the selected Security Erase features.
- **HDD User Pwd Status:** This feature indicates if a password has been set as a storage device user password, which enables configuring Supermicro Security Erase settings on this storage device.
- **TCG Device Type:** This feature displays the TCG device type detected by the system.
- **Admin Pwd Status:** This feature indicates if a password has been set as a storage device administrator password, which enables configuring Supermicro Security Erase settings on this storage device.

Note: This submenu is available when any storage device is detected by the BIOS. For more information about this feature, refer to our website.

Lockdown Mode (Available when the DCMS key is activated)

Select Enabled to support the Lockdown Mode, which prevents the existing data or keys stored in the system from being altered or changed in an effort to preserve system integrity and security. The options are **Disabled** and Enabled.

► Secure Boot

The following information is displayed:

- System Mode
- Secure Boot

Note: For detailed instructions on configuring Security Boot settings, refer to the Security Boot Configuration User's Guide at <https://www.supermicro.com/support/manuals>.

7.7 Boot

Use this menu to configure Boot settings.

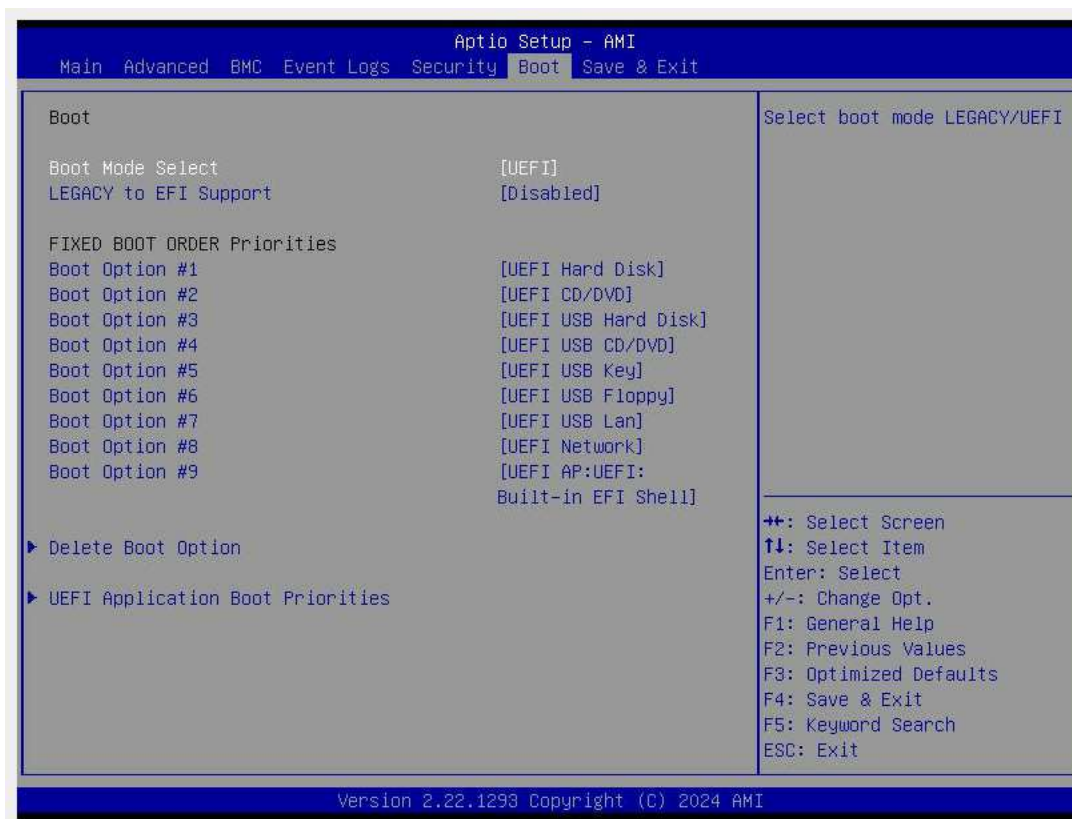

Figure 7-6. Boot

Boot

Boot Mode Select

Use this feature to select boot mode. The options are Legacy, **UEFI**, and Dual.

Legacy to EFI Support

Use this feature to enable system to boot to EFI OS after boot failed from legacy boot order. The options are **Disabled** and Enabled.

Fixed Boot Order Priorities

Use this feature to prioritize the order of a bootable device from which the system will boot. Press <Enter> on each item sequentially to select the device.

- Boot Option #1 – Boot Option #9

► Add New Boot Option

Use this feature to add a new boot option to the boot priority features for system boot.

Note: This submenu is available when any storage device is detected by the BIOS.

Add boot option

Use this feature to specify the name for the new boot option.

Path for boot option

Use this feature to enter the path for the new boot option in the format fsx:\path\filename.efi.

Boot option File Path

Use this feature to specify the file path for the new boot option.

Create

After setting the name and the file path for the boot option, press <Enter> to create the new boot option in the boot priority list.

▶ Delete Boot Option

Use this feature to remove an EFI boot option from the boot order

Delete Boot Option

Use this feature to remove an EFI boot option from the boot order. The options are **Select One to Delete** and UEFI: Built-in EFI Shell.

UEFI Application Boot Option

This setting specifies the primary UEFI application to boot from. The options are **UEFI: Built-in EFI Shell** and Disabled.

▶ UEFI USB Key Drive BBS Priorities

Use this feature to set the system boot order of detected devices.

▶ UEFI NETWORK Drive BBS Priorities

Use this feature to set the system boot order of detected devices.

▶ UEFI Application Boot Priorities

Use this feature to set the system boot order of detected devices.

7.8 Save & Exit

Select Save & Exit from the BIOS Setup screen to configure the settings below.

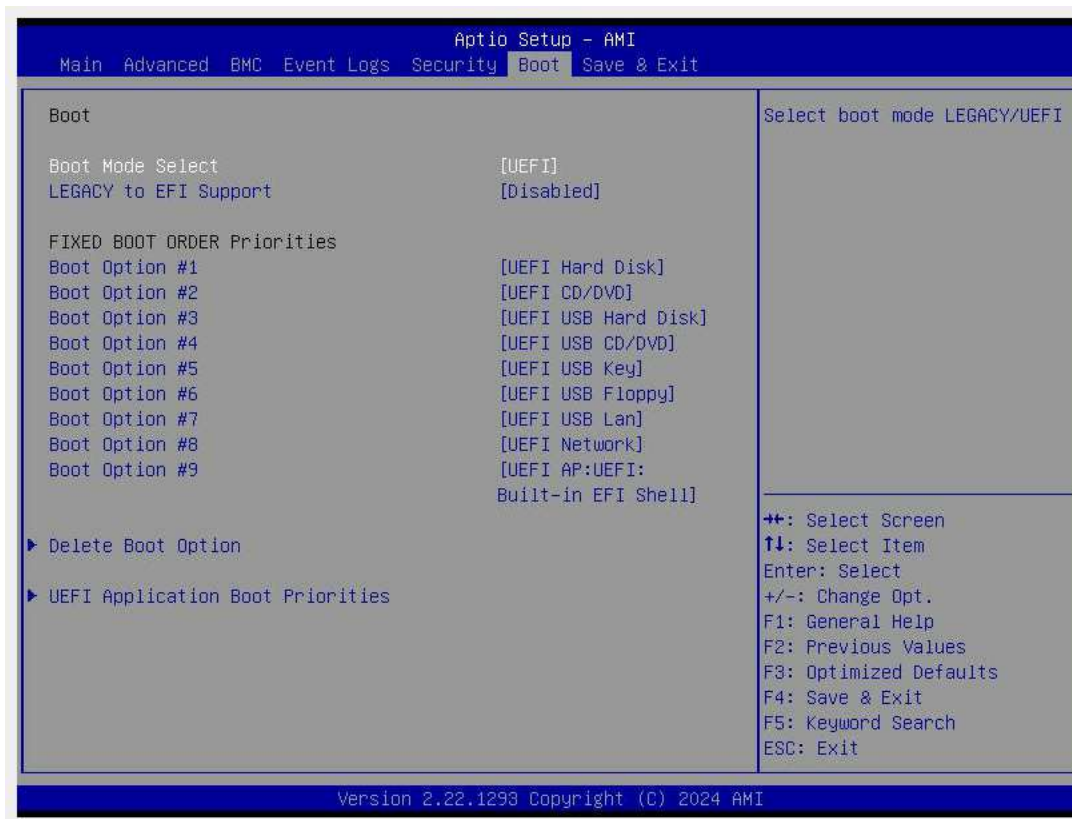

Figure 7-7. Save & Exit Screen

Save Options

Discard Changes and Exit

Select this option and press <Enter> to discard all the changes you've made and return to the AMI BIOS setup utility.

Save Changes and Reset

When you have completed the system configuration changes, select this option to leave the BIOS setup utility and reboot the computer for the new system configuration parameters to become effective.

Save Changes

When you have completed the system configuration changes, select this option to save all changes made. This will not reset (reboot) the system.

Discard Changes

When you have completed the system configuration changes, select this option to leave the BIOS setup utility and reboot the computer for the new system configuration parameters to become effective.

Default Options**Restore Optimized Defaults**

To set this feature, select Restore Defaults from the Exit menu and press <Enter> to load manufacturer default settings which are intended for maximum system performance but not for maximum stability.

Note: Please reboot the system for the changes to take effect, which ensures that this system has the optimized default settings.

Save as User Defaults

To set this feature, select Save as User Defaults from the Exit menu and press <Enter>. This enables the user to save all changes to the BIOS setup for future use.

Restore User Defaults

To set this feature, select Restore User Defaults from the Exit menu and press <Enter>. Use this feature to retrieve user-defined default settings that were saved previously.

Boot Override

Note: Use this section to override the Boot priorities sequence in the Boot menu, and immediately boot the system with a device specified here instead of the one specified in the boot list. This is a one-time boot override.

Launch EFI Shell from filesystem device

Use this feature to launch the EFI shell application (Shell.efi) from one of the available filesystem devices. A filesystem is a virtual, logical, or physical system for organizing, managing, and accessing the files and directories on devices such as SSDs, HDDs, or other storage devices.

Appendix A:

BIOS Codes

For information about BIOS codes for the AS -5126GS-TNRT/-TNRT2 server, refer to the following content.

BIOS Error POST (Beep) Codes

During the Power-On Self-Test (POST) routines, which are performed each time the system is powered on, errors may occur.

Non-fatal errors are those which, in most cases, allow the system to continue the boot up process. The error messages normally appear on the screen.

Fatal errors are those which will not allow the system to continue the boot up process. If a fatal error occurs, you should consult with your system manufacturer for possible repairs.

These fatal errors are usually communicated through a series of audible beeps that can be heard on an external buzzer connected to JD1. The table shown below lists some common errors and their corresponding beep codes encountered by users.

BIOS Beep (POST) Codes		
Beep Code	Error Message	Description
1 beep	Refresh	Circuits have been reset (Ready to power up)
5 short, 1 long	Memory error	No memory detected in system
5 short, 2 long	Display memory read/write error	Video adapter missing or with faulty memory
1 long continuous	System OH	System overheat condition

Additional BIOS POST Codes

The AMI BIOS supplies additional checkpoint codes, which are documented online at <https://www.supermicro.com/support/manuals> ("AMI BIOS POST Codes User's Guide").

For information on AMI updates, refer to <https://www.ami.com/products>.

Appendix B:

Standardized Warning Statements for AC Systems

The following statements are industry standard warnings, provided to warn the user of situations which have the potential for bodily injury. Should you have questions or experience difficulty, contact Supermicro's Technical Support department for assistance. Only certified technicians should attempt to install or configure components.

Read this section in its entirety before installing or configuring components in the Supermicro AS -5126GS-TNRT/-TNRT2 server.

These warnings may also be found on our website at the following page:

https://www.supermicro.com/about/policies/safety_information.cfm

Warning Definition



Warning! This warning symbol means danger. You are in a situation that could cause bodily injury. Before you work on any equipment, be aware of the hazards involved with electrical circuitry and be familiar with standard practices for preventing accidents.

警告の定義

この警告サインは危険を意味します。

人身事故につながる可能性がありますので、いずれの機器でも動作させる前に、電気回路に含まれる危険性に注意して、標準的な事故防止策に精通して下さい。

此警告符号代表危險。

您正处于可能受到严重伤害的工作环境中。在您使用设备开始工作之前，必须充分意识到触电的危险，并熟练掌握防止事故发生的标准工作程序。请根据每项警告结尾的声明号码找到此设备的安全性警告说明的翻译文本。

此警告符號代表危險。

您正處於可能身體可能會受損傷的工作環境中。在您使用任何設備之前，請注意觸電的危險，並且要熟悉預防事故發生的標準工作程序。請依照每一注意事項後的號碼找到相關的翻譯說明內容。

Warnung

WICHTIGE SICHERHEITSHINWEISE

Dieses Warnsymbol bedeutet Gefahr. Sie befinden sich in einer Situation, die zu Verletzungen führen kann. Machen Sie sich vor der Arbeit mit Geräten mit den Gefahren elektrischer Schaltungen und den üblichen Verfahren zur Vorbeugung vor Unfällen vertraut. Suchen Sie mit der am Ende jeder Warnung angegebenen Anweisungsnummer nach der jeweiligen Übersetzung in den übersetzten Sicherheitshinweisen, die zusammen mit diesem Gerät ausgeliefert wurden.

BEWAHREN SIE DIESE HINWEISE GUT AUF.

INSTRUCCIONES IMPORTANTES DE SEGURIDAD

Este símbolo de aviso indica peligro. Existe riesgo para su integridad física. Antes de manipular cualquier equipo, considere los riesgos de la corriente eléctrica y familiarícese con los procedimientos estándar de prevención de accidentes. Al final de cada advertencia encontrará el número que le ayudará a encontrar el texto traducido en el apartado de traducciones que acompaña a este dispositivo.

GUARDE ESTAS INSTRUCCIONES.

IMPORTANTES INFORMATIONS DE SÉCURITÉ

Ce symbole d'avertissement indique un danger. Vous vous trouvez dans une situation pouvant entraîner des blessures ou des dommages corporels. Avant de travailler sur un équipement, soyez conscient des dangers liés aux circuits électriques et familiarisez-vous avec les procédures couramment utilisées pour éviter les accidents. Pour prendre connaissance des traductions des avertissements figurant dans les consignes de sécurité traduites qui accompagnent cet appareil, référez-vous au numéro de l'instruction situé à la fin de chaque avertissement.

CONSERVEZ CES INFORMATIONS.

תקנון הצהרות אזהרה

הצהרות הבאות הן אזהרות על פי תקני התעשייה, על מנת להזהיר את המשתמש מפני חבלה פיזית אפשרית. במידה ויש שאלות או היתקלות בבעיה כלשהי, יש ליצור קשר עם מחלקת תמיכה טכנית של סופרמיקרו. טכנאים מוסמכים בלבד רשאים להתקין או להגדיר את הרכיבים. יש לקרוא את הנספח במלואו לפני התקנת או הגדרת הרכיבים במארזי סופרמיקרו.

الكافة حالة وكي أي تتسبب ف اصابة جسده هذا الزهر ع خطر! تحذّر.
قبل أي تعول على أي هعدات، كي على علن بالوخاظر ال اجوة عي النوانز
الكهربائ ة

وكي على دراة بالووارسات النقاء ة لو ع وقع أي حداثث
استخدم رقن الب إى الو صنص ف هاة كل تحذّر للعنثر تزجوتها

안전을 위한 주의사항

경고!

이 경고 기호는 위험이 있음을 알려 줍니다. 작업자의 신체에 부상을 야기 할 수 있는 상태에 있게 됩니다. 모든 장비에 대한 작업을 수행하기 전에 전기회로와 관련된 위험요소들을 확인하시고 사전에 사고를 방지할 수 있도록 표준 작업절차를 준수해 주시기 바랍니다.

해당 번역문을 찾기 위해 각 경고의 마지막 부분에 제공된 경고문 번호를 참조하십시오

BELANGRIJKE VEILIGHEIDSINSTRUCTIES

Dit waarschuwings symbool betekent gevaar. U verkeert in een situatie die lichamelijk letsel kan veroorzaken. Voordat u aan enige apparatuur gaat werken, dient u zich bewust te zijn van de bij een elektrische installatie betrokken risico's en dient u op de hoogte te zijn van de standaard procedures om ongelukken te voorkomen. Gebruik de nummers aan het eind van elke waarschuwing om deze te herleiden naar de desbetreffende locatie.

BEWAAR DEZE INSTRUCTIES

Installation Instructions



Warning! Read the installation instructions before connecting the system to the power source.

設置手順書

システムを電源に接続する前に、設置手順書をお読み下さい。

警告

将此系统连接电源前,请先阅读安装说明。

警告

將系統與電源連接前,請先閱讀安裝說明。

Warnung

Vor dem Anschließen des Systems an die Stromquelle die Installationsanweisungen lesen.

¡Advertencia!

Lea las instrucciones de instalación antes de conectar el sistema a la red de alimentación.

Attention

Avant de brancher le système sur la source d'alimentation, consulter les directives d'installation.

יש לקרוא את הוראות התקנה לפני חיבור המערכת למקור מתח.

اقرأ إرشادات التركيب قبل توصيل النظام إلى مصدر للطاقة

시스템을 전원에 연결하기 전에 설치 안내를 읽어주십시오.

Waarschuwing

Raadpleeg de installatie-instructies voordat u het systeem op de voedingsbron aansluit.

Circuit Breaker



Warning! This product relies on the building's installation for short-circuit (overcurrent) protection. Ensure that the protective device is rated not greater than: 250 V, 20 A.

サーキット・ブレーカー

この製品は、短絡(過電流)保護装置がある建物での設置を前提としています。

保護装置の定格が250 V、20 Aを超えないことを確認下さい。

警告

此产品的短路(过载电流)保护由建筑物的供电系统提供,确保短路保护设备的额定电流不大于 250V,20A。

警告

此產品的短路(過載電流)保護由建築物的供電系統提供,確保短路保護設備的額定電流不大於 250V,20A。

Warnung

Dieses Produkt ist darauf angewiesen, dass im Gebäude ein Kurzschluss- bzw. Überstromschutz installiert ist. Stellen Sie sicher, dass der Nennwert der Schutzvorrichtung nicht mehr als: 250 V, 20 A beträgt.

¡Advertencia!

Este equipo utiliza el sistema de protección contra cortocircuitos (o sobrecorrientes) del edificio. Asegúrese de que el dispositivo de protección no sea superior a: 250 V, 20 A.

Attention

Pour ce qui est de la protection contre les courts-circuits (surtension), ce produit dépend de l'installation électrique du local. Vérifiez que le courant nominal du dispositif de protection n'est pas supérieur à :250 V, 20 A.

מוצר זה מסתמך על הגנה המותקנת במבנים למניעת קצר חשמלי. יש לוודא כי

המכשיר המגן מפני הקצר החשמלי הוא לא יותר מ-250V, 20A

هذا المنتج يعتمد على معدات الحماية من الدوائر القصيرة التي تم تثبيتها في

المبنى

تأكد من أن تقييم الجهاز الوقائي ليس أكثر من : 20A, 250V

경고!

이 제품은 전원의 단락(과전류)방지에 대해서 전적으로 건물의 관련 설비에 의존합니다. 보호장치의 정격이 반드시 250V(볼트), 20A(암페어)를 초과하지 않도록 해야 합니다.

Waarschuwing

Dit product is afhankelijk van de kortsluitbeveiliging (overspanning) van uw elektrische installatie. Controleer of het beveiligde apparaat niet groter gedimensioneerd is dan 250V, 20A.

Power Disconnection Warning



Warning! The system must be disconnected from all sources of power and the power cord removed from the power supply module(s) before accessing the chassis interior to install or remove system components (except for hot-swap components).

電源切断の警告

システムコンポーネントの取り付けまたは取り外しのために、シャーシ内部にアクセスするには、システムの電源はすべてのソースから切断され、電源コードは電源モジュールから取り外す必要があります。

警告

在你打开机箱并安装或移除内部器件前,必须将系统完全断电,并移除电源线。

警告

在您打開機殼安裝或移除內部元件前,必須將系統完全斷電,並移除電源線。

Warnung

Das System muss von allen Quellen der Energie und vom Netzanschlusskabel getrennt sein, das von den Spg.Versorgungsteilmodulen entfernt wird, bevor es auf den Chassisinnenraum zurückgreift, um Systemsbestandteile anzubringen oder zu entfernen.

¡Advertencia!

El sistema debe ser disconnected de todas las fuentes de energía y del cable eléctrico quitado de los módulos de fuente de alimentación antes de tener acceso el interior del chasis para instalar o para quitar componentes de sistema.

Attention

Le système doit être débranché de toutes les sources de puissance ainsi que de son cordon d'alimentation secteur avant d'accéder à l'intérieur du châssis pour installer ou enlever des composants de système.

אזהרה מפני ניתוק חשמלי

אזהרה!

יש לנתק את המערכת מכל מקורות החשמל ויש להסיר את כבל החשמלי מהספק לפני גישה לחלק הפנימי של המארז לצורך התקנת או הסרת רכיבים.

يجب فصل المنظمو من جميع مصادر انطاقت وإزانت سهك انكهرباء من وحدة امداد انطاقت قيم

انصلل إلى انمناطق انداخهيت نههيكم ننتشيج أو إزانت مكنناث الجهاز

경고!

시스템에 부품들을 장착하거나 제거하기 위해서는 새시 내부에 접근하기 전에 반드시 전원 공급장치로부터 연결되어있는 모든 전원과 전기코드를 분리해주어야 합니다.

Waarschuwing

Voordat u toegang neemt tot het binnenwerk van de behuizing voor het installeren of verwijderen van systeem onderdelen, dient u alle spanningsbronnen en alle stroomkabels aangesloten op de voeding(en) van de behuizing te verwijderen

Equipment Installation



Warning! Only authorized personnel and qualified service persons should be allowed to install, replace, or service this equipment.

機器の設置

トレーニングを受け認定された人だけがこの装置の設置、交換、またはサービスを許可されています。

警告

只有经过培训且具有资格的人员才能进行此设备的安装、更换和维修。

警告

只有經過受訓且具資格人員才可安裝、更換與維修此設備。

Warnung

Nur autorisiertes Personal und qualifizierte Servicetechniker dürfen dieses Gerät installieren, austauschen oder warten.

¡Advertencia!

Sólo el personal autorizado y el personal de servicio calificado deben poder instalar, reemplazar o dar servicio a este equipo.

Attention

Seul le personnel autorisé et le personnel de maintenance qualifié doivent être autorisés à installer, remplacer ou entretenir cet équipement.

אזהרה!

יש לאפשר רק צוות מורשה ואנשי שירות מוסמכים להתקין, להחליף או לטפל בצידוד זה

ينبغي السماح فقط للموظفين المعتمدين وأفراد الخدمة المؤهلين بتركيب هذا الجهاز أو استبداله أو صيانته

경고!

승인된 직원과 자격을 갖춘 서비스 담당자만이 이 장비를 설치, 교체 또는 서비스할 수 있습니다.

Waarschuwing

Alleen geautoriseerd personeel en gekwalificeerd onderhoudspersoneel mag deze apparatuur installeren, vervangen of onderhouden.

Restricted Area



Warning! This unit is intended for installation in restricted access areas. A restricted access area can be accessed only through the use of a special tool, lock and key, or other means of security. (This warning does not apply to workstations).

アクセス制限区域

このユニットは、アクセス制限区域に設置されることを想定しています。

アクセス制限区域は、特別なツール、鍵と錠前、その他のセキュリティの手段を用いてのみ出入りが可能です。

警告

此部件应安装在限制进出的场所，限制进出的场所指只能通过使用特殊工具、锁和钥匙或其它安全手段进出的场所。

警告

此装置僅限安裝於進出管制區域，進出管制區域係指僅能以特殊工具、鎖頭及鑰匙或其他安全方式才能進入的區域。

Warnung

Diese Einheit ist zur Installation in Bereichen mit beschränktem Zutritt vorgesehen. Der Zutritt zu derartigen Bereichen ist nur mit einem Spezialwerkzeug, Schloss und Schlüssel oder einer sonstigen Sicherheitsvorkehrung möglich.

¡Advertencia!

Esta unidad ha sido diseñada para instalación en áreas de acceso restringido. Sólo puede obtenerse acceso a una de estas áreas mediante la utilización de una herramienta especial, cerradura con llave u otro medio de seguridad.

Attention

Cet appareil doit être installée dans des zones d'accès réservés. L'accès à une zone d'accès réservé n'est possible qu'en utilisant un outil spécial, un mécanisme de verrouillage et une clé, ou tout autre moyen de sécurité.

אזור עם גישה מוגבלת

אזהרה!

יש להתקין את היחידה באזורים שיש בהם הגבלת גישה. הגישה ניתנת בעזרת כלי אבטחה בלבד (מפתח, מנעול וכד.).

اتخصيص هذه انحدة نترك بها ف مناطق محظورة تم .

ممكن انصلل إن منطقت محظورة فقط من خلال استخدام أداة خاصت،

أو أوس هت أخري نلاأما ققم ومفتاح

경고!

이 장치는 접근이 제한된 구역에 설치하도록 되어있습니다. 특수도구, 잠금 장치 및 키, 또는 기타 보안 수단을 통해서만 접근 제한 구역에 들어갈 수 있습니다.

Waarschuwing

Dit apparaat is bedoeld voor installatie in gebieden met een beperkte toegang. Toegang tot dergelijke gebieden kunnen alleen verkregen worden door gebruik te maken van speciaal gereedschap, slot en sleutel of andere veiligheidsmaatregelen.

Battery Handling



CAUTION There is risk of explosion if the battery is replaced by an incorrect type. Replace the battery only with the same or equivalent type recommended by the manufacturer. Dispose of used batteries according to the manufacturer's instructions.

電池の取り扱い

バッテリーを間違ったタイプに交換すると爆発の危険があります。交換する電池はメーカーが推奨する型、または同等のものを使用下さい。使用済電池は製造元の指示に従って処分して下さい。

警告

如果更换的电池类型不正确。请只使用同类电池或制造商推荐的功能相当的电池更换原有电池。请按制造商的说明处理废旧电池。

警告

如果更換的電池類型不正確。請使用製造商建議之相同或功能相當的電池更換原有電池。請按照製造商的說明指示處理廢棄舊電池。

WARNUNG

Es besteht Explosionsgefahr, wenn die Batterie durch einen falschen Typ ersetzt wird. Ersetzen Sie die Batterie nur durch den gleichen oder vom Hersteller empfohlenen Batterietyp. Entsorgen Sie die benutzten Batterien nach den Anweisungen des Herstellers.

ADVERTENCIA

Existe riesgo de explosión si la batería se reemplaza por un tipo incorrecto. Reemplazar la batería exclusivamente con el mismo tipo o el equivalente recomendado por el fabricante. Desechar las baterías gastadas según las instrucciones del fabricante.

ATTENTION

Il existe un risque d'explosion si la batterie est remplacée par un type incorrect. Ne la remplacer que par une pile de type semblable ou équivalent, recommandée par le fabricant. Jeter les piles usagées conformément aux instructions du fabricant.

אזהרה!

קיימת סכנת פיצוץ אם הסוללה תוחלף בסוג שגוי. יש להחליף את הסוללה בסוג התואם מחברת יצרן מומלצת. סילוק הסוללות המשומשות יש לבצע לפי הוראות היצרן.

هناك خطر الانفجار إذا تم استبدال البطارية بنوع غير صحيح

استبدال البطارية

فقط بنفس النوع أو ما يعادلها مما أوصت به الشركة المصنعة

جخلص من البطاريات المسحمة وفقاً لتعليمات الشركة الصانعة

경고!

배터리를 잘못된 종류로 교체하면 폭발의 위험이 있습니다. 기존 배터리와 동일하거나 제조사에서 권장하는 동등한 종류의 배터리로만 교체해야 합니다. 제조사의 안내에 따라 사용된 배터리를 처리하여 주십시오.

WAARSCHUWING

Er bestaat explosiegevaar als de batterij wordt vervangen door een verkeerd type. Vervang de batterij slechts met hetzelfde of een equivalent type die door de fabrikant aanbevolen wordt. Gebruikte batterijen dienen overeenkomstig fabrieksvoorschriften afgevoerd te worden.

Redundant Power Supplies

Warning! This unit might have more than one power supply connection. All connections must be removed to de-energize the unit.

冗長電源装置

このユニットは複数の電源装置が接続されている場合があります。

ユニットの電源を切るためには、すべての接続を取り外さなければなりません。

警告

此部件连接的电源可能不止一个，必须将所有电源断开才能停止给该部件供电。

警告

此装置连接的电源可能不只一个，必须切断所有电源才能停止对该装置的供电。

Warnung

Dieses Gerät kann mehr als eine Stromzufuhr haben. Um sicherzustellen, dass der Einheit kein Strom zugeführt wird, müssen alle Verbindungen entfernt werden.

¡Advertencia!

Puede que esta unidad tenga más de una conexión para fuentes de alimentación. Para cortar por completo el suministro de energía, deben desconectarse todas las conexiones.

Attention

Cette unité peut avoir plus d'une connexion d'alimentation. Pour supprimer toute tension et tout courant électrique de l'unité, toutes les connexions d'alimentation doivent être débranchées.

אם קיים יותר מספק אחד

אזהרה!

ליחידה יש יותר מחיבור אחד של ספק. יש להסיר את כל החיבורים על מנת לרוקן

את היחידה.

قد يكون لهذا الجهاز عدة اتصالات بوحدات امداد الطاقة .

يجب إزالة كافة الاتصالات لعزل الوحدة عن الكهرباء

경고!

이 장치에는 한 개 이상의 전원 공급 단자가 연결되어 있을 수 있습니다. 이 장치에 전원을 차단하기 위해서는 모든 연결 단자를 제거해야만 합니다.

Waarschuwing

Deze eenheid kan meer dan één stroomtoevoeraansluiting bevatten. Alle aansluitingen dienen verwijderd te worden om het apparaat stroomloos te maken.

Backplane Voltage



Warning! Hazardous voltage or energy is present on the backplane when the system is operating. Use caution when servicing.

バックプレーンの電圧

システムの稼働中は危険な電圧または電力が、バックプレーン上にかかっています。

修理する際には注意ください。

警告

当系统正在进行时，背板上有很危险的电压或能量，进行维修时务必小心。

警告

當系統正在進行時，背板上有危險的電壓或能量，進行維修時務必小心。

Warnung

Wenn das System in Betrieb ist, treten auf der Rückwandplatine gefährliche Spannungen oder Energien auf. Vorsicht bei der Wartung.

¡Advertencia!

Cuando el sistema está en funcionamiento, el voltaje del plano trasero es peligroso. Tenga cuidado cuando lo revise.

Attention

Lorsque le système est en fonctionnement, des tensions électriques circulent sur le fond de panier. Prendre des précautions lors de la maintenance.

מתח בפנל האחורי

אזהרה!

קיימת סכנת מתח בפנל האחורי בזמן תפעול המערכת. יש להיזהר במהלך

העבודה.

هناك خطر من التيار الكهربائي أو الطاقة المخزنة على اللوحة

عندما يكون النظام يعمل كه حذرا عند خدمة هذا الجهاز

경고!

시스템이 동작 중일 때 후면판 (Backplane)에는 위험한 전압이나 에너지가 발생 합니다. 서비스 작업 시 주의하십시오.

Waarschuwing

Een gevaarlijke spanning of energie is aanwezig op de backplane wanneer het systeem in gebruik is. Voorzichtigheid is geboden tijdens het onderhoud.

Comply with Local and National Electrical Codes



Warning! Installation of the equipment must comply with local and national electrical codes.

地方および国の電気規格に準拠

機器の取り付けはその地方および国の電気規格に準拠する必要があります。

警告

设备安装必须符合本地与本国电气法规。

警告

設備安裝必須符合本地與本國電氣法規。

Warnung

Die Installation der Geräte muss den Sicherheitsstandards entsprechen.

¡Advertencia!

La instalacion del equipo debe cumplir con las normas de electricidad locales y nacionales.

Attention

L'équipement doit être installé conformément aux normes électriques nationales et locales.

תיאום חוקי החשמל הארצי

אזהרה!

התקנת הציוד חייבת להיות תואמת לחוקי החשמל המקומיים והארציים.

تركيب المعدات الكهربائية يجب أن يمتثل للقوانين المحلية والنظمية المتعلقة

بالكهرباء

경고!

현 지역 및 국가의 전기 규정에 따라 장비를 설치해야 합니다.

Waarschuwing

Bij installatie van de apparatuur moet worden voldaan aan de lokale en nationale elektriciteitsvoorschriften.

Product Disposal



Warning! Ultimate disposal of this product should be handled according to all national laws and regulations.

製品の廃棄

この製品を廃棄処分する場合、国の関係する全ての法律・条例に従い処理する必要があります。

警告

本产品的废弃处理应根据所有国家的法律和规章进行。

警告

本產品的廢棄處理應根據所有國家的法律和規章進行。

Warnung

Die Entsorgung dieses Produkts sollte gemäß allen Bestimmungen und Gesetzen des Landes erfolgen.

¡Advertencia!

Al deshacerse por completo de este producto debe seguir todas las leyes y reglamentos nacionales.

Attention

La mise au rebut ou le recyclage de ce produit sont généralement soumis à des lois et/ou directives de respect de l'environnement. Renseignez-vous auprès de l'organisme compétent.

סילוק המוצר

אזהרה!

סילוק סופי של מוצר זה חייב להיות בהתאם להנחיות וחוקי המדינה.

عند التخلص النهائي من هذا المنتج ينبغي التعامل معه وفقا لجميع القوانين واللوائح الوطنية

경고!

이 제품은 해당 국가의 관련 법규 및 규정에 따라 폐기되어야 합니다.

Waarschuwing

De uiteindelijke verwijdering van dit product dient te geschieden in overeenstemming met alle nationale wetten en reglementen.

Fan Warning



Warning! Hazardous moving parts. Keep away from moving fan blades. The fans might still be turning when you remove the fan assembly from the chassis. Keep fingers, screwdrivers, and other objects away from the openings in the fan assembly's housing



ファンの警告

警告！回転部品に注意。運転中は回転部(羽根)に触れないでください。シャーシから冷却ファン装置を取り外した際、ファンがまだ回転している可能性があります。ファンの開口部に、指、ドライバー、およびその他のものを近づけないで下さい。

警告!

警告! 危险的可移动性零件。请务必与转动的风扇叶片保持距离。当您从机架移除风扇装置, 风扇可能仍在转动。小心不要将手指、螺丝起子和其他物品太靠近风扇

警告

危險的可移動性零件。請務必與轉動的風扇葉片保持距離。當您從機架移除風扇裝置, 風扇可能仍在轉動。小心不要將手指、螺絲起子和其他物品太靠近風扇。

Warnung

Gefährlich Bewegende Teile. Von den bewegenden Lüfterblätter fern halten. Die Lüfter drehen sich u. U. noch, wenn die Lüfterbaugruppe aus dem Chassis genommen wird. Halten Sie Finger, Schraubendreher und andere Gegenstände von den Öffnungen des Lüftergehäuses entfernt.

¡Advertencia!

Riesgo de piezas móviles. Mantener alejado de las aspas del ventilador. Los ventiladores podran dar vuelta cuando usted quite el montaje del ventilador del chasis. Mantenga los dedos, los destornilladores y todos los objetos lejos de las aberturas del ventilador.

Attention

Pieces mobiles dangereuses. Se tenir a l'écart des lames du ventilateur Il est possible que les ventilateurs soient toujours en rotation lorsque vous retirerez le bloc ventilateur du châssis. Prenez garde à ce que doigts, tournevis et autres objets soient éloignés du logement du bloc ventilateur.

אזהרה!

חלקים נעים מסוכנים. התרחק מלהבי המאוורר בפעולהכאשר מסירים את חלקי המאוורר מהמארז, יתכן והמאווררים עדיין עובדים. יש להרחיק למרחק בטוח את האצבעות וכלי עבודה שונים מהפתחים בתוך המאוורר

تحذير! أجزاء متحركة خطيرة. ابتعد عن شفرات المروحة المتحركة. من الممكن أن المراوح لا تزال تدور عند إزالة كتلة المروحة من الهيكل يجب إبقاء الأصابع ومفكات البراغي وغيرها من الأشياء بعيدا عن الفتحات في كتلة المروحة.

경고!

움직이는 위험한 부품. 회전하는 송풍 날개에 접근하지 마세요. 새시로부터 팬 조립품을 제거할 때 팬은 여전히 회전하고 있을 수 있습니다. 팬 조립품 외관의 열려있는 부분들로부터 손가락 및 스크류드라이버, 다른 물체들이 가까이 하지 않도록 배치해 주십시오.

Waarschuwing

Gevaarlijk bewegende onderdelen. Houd voldoende afstand tot de bewegende ventilatorbladen. Het is mogelijk dat de ventilator nog draait tijdens het verwijderen van het ventilatorsamenstel uit het chassis. Houd uw vingers, schroevendraaiers en eventuele andere voorwerpen uit de buurt van de openingen in de ventilatorbehuizing.

Power Cable and AC Adapter



Warning! When installing the product, use the provided or designated connection cables, power cables and AC adaptors. Using any other cables and adaptors could cause a malfunction or a fire. Electrical Appliance and Material Safety Law prohibits the use of UL or CSA -certified cables (that have UL/CSA shown on the cord) for any other electrical devices than products designated by Supermicro only.

電源コードとACアダプター

製品を設置する場合、提供または指定および購入された接続ケーブル、電源コードとACアダプターを該当する地域の条例や安全基準に適合するコードサイズやプラグと共に使用下さい。他のケーブルやアダプタを使用すると故障や火災の原因になることがあります。

電気用品安全法は、ULまたはCSA認定のケーブル(UL/CSAマークがコードに表記)をSupermicroが指定する製品以外に使用することを禁止しています。

警告

安裝此產品時,請使用本身提供的或指定的或採購的連接線,電源線和電源適配器,包含遵照當地法規和安全要求的合規的電源線尺寸和插頭.使用其它線材或適配器可能會引起故障或火災。除了 Supermicro 所指定的產品,電氣用品和材料安全法律規定禁止使用未經 UL 或 CSA 認證的線材。(線材上會顯示 UL/CSA 符號)。

警告

安裝此產品時,請使用本身提供的或指定的或採購的連接線,電源線和電源適配器,包含遵照當地法規和安全要求的合規的電源線尺寸和插頭.使用其它線材或適配器可能會引起故障或火災。除了 Supermicro 所指定的產品,電氣用品和材料安全法律規定禁止使用未經 UL 或 CSA 認證的線材。(線材上會顯示 UL/CSA 符號)。

Warnung

Nutzen Sie beim Installieren des Produkts ausschließlich die von uns zur Verfügung gestellten Verbindungskabeln, Stromkabeln und/oder Adapter, die Ihre örtlichen Sicherheitsstandards einhalten. Der Gebrauch von anderen Kabeln und Adapter können Fehlfunktionen oder Feuer verursachen. Die Richtlinien untersagen das Nutzen von UL oder CAS zertifizierten Kabeln (mit UL/CSA gekennzeichnet), an Geräten oder Produkten die nicht mit Supermicro gekennzeichnet sind.

¡Advertencia!

Cuando instale el producto, utilice la conexión provista o designada o procure cables, Cables de alimentación y adaptadores de CA que cumplan con los códigos locales y los requisitos de seguridad, incluyendo el tamaño adecuado del cable y el enchufe. El uso de otros cables y adaptadores podría causar un mal funcionamiento o un incendio. La Ley de Seguridad de Aparatos Eléctricos y de Materiales prohíbe El uso de cables certificados por UL o CSA (que tienen el certificado UL / CSA en el código) para cualquier otros dispositivos eléctricos que los productos designados únicamente por Supermicro.

Attention

Lors de l'installation du produit, utilisez les câbles de connection fournis ou désigné ou achetez des câbles, câbles de puissance et adaptateurs respectant les normes locales et les conditions de sécurité y compris les tailles de câbles et les prises électriques appropriées. L'utilisation d'autres câbles et adaptateurs peut provoquer un dysfonctionnement ou un incendie. Appareils électroménagers et la Loi sur la Sécurité Matériel interdit l'utilisation de câbles certifiés- UL ou CSA (qui ont UL ou CSA indiqué sur le code) pour tous les autres appareils électriques sauf les produits désignés par Supermicro seulement.

AC ימאתמו םיילמשח םילבכ

הרהזא!

ךרוצל ומאתוה וא ושכרנ רשא AC םימאתמו םיקפס, םילבכב שמתשהל שי, רצומה תא םיניקתמ רשאכ לכב שומיש . עקתהו לבכה לש הנוכנ הדימ ללוכ, תוימוקמה תוחיטבה תושירדל ומאתוה רשאו, הנקתהה למשחה ירישכמב שומישה יקוחל סאתהב . ילמשח רצק וא הלקתל סורגל לולע, רחא גוסמ סאתמ וא לבכ לש דוק םהילע עיפומ רשאכ) CSA- ב וא UL - ב םיכסומה םילבכב שמתשהל רוסיא םייק, תוחיטבה יקוחו דבלב Supermicro י"ע סאתוה רשא רצומב קר אלא, רחא ילמשח רצומ לכ רובע (UL/CSA).

תאלבאקלא ׁארשב مق وأ ءددمحلا وأ ءرفوتملا تاليصوتلا مادختساب مق ،جتئملا بيكرت دنع

كلذ يف امب ءيلحملا ءمالسلا تابلطتمو نيناوقب ماز تلالا عم ددرتملا رايتلا تالوحمو ءيناوبرهكلا

قيرح وأ لطح يف ببستي دق برخأ تالوحمو تالباك يا مادختسا .ميلسلا سباقلاو لصوملا مجح .

CSA وأ UL لبق نم ءدمتعملا تالباكلا مادختسا تادعملاو ءيناوبرهكلا ءز هجالل ءمالسلا نوناق رظحي

Supermicro لبق نم ءددمحلاو ءينعملا تاجتئملا ريغ برخأ تادعم يا عم (UL/CSA) ءمالع لمحت يتلاو .

전원 케이블 및 AC 어댑터

경고! 제품을 설치할 때 현지 코드 및 적절한 굵기의 코드와 플러그를 포함한 안전 요구 사항을 준수하여 제공되거나 지정된 연결 혹은 구매 케이블, 전원 케이블 및 AC 어댑터를 사용하십시오.

다른 케이블이나 어댑터를 사용하면 오작동이나 화재가 발생할 수 있습니다. 전기 용품 안전법은 UL 또는 CSA 인증 케이블 (코드에 UL / CSA가 표시된 케이블)을 Supermicro 가 지정한 제품 이외의 전기 장치에 사용하는 것을 금지합니다.

Stroomkabel en AC-Adapter

Waarschuwing! Bij het aansluiten van het Product uitsluitend gebruik maken van de geleverde Kabels of een andere geschikte aan te schaffen Aansluitmethode, deze moet altijd voldoen aan de lokale voorschriften en veiligheidsnormen, inclusief de juiste kabeldikte en stekker. Het gebruik van niet geschikte Kabels en/of Adapters kan een storing of brand veroorzaken. Wetgeving voor Elektrische apparatuur en Materiaalveiligheid verbied het gebruik van UL of CSA -gecertificeerde Kabels (met UL/CSA in de code) voor elke andere toepassing dan de door Supermicro hiervoor beoogde Producten.

Appendix C:

System Specifications

Processors

Dual AMD EPYC™ 9005/9004 Series Processors in Socket SP5 and a Thermal Design Power up to 500 W

Chipset

System on Chip

BIOS

AMI 64 MB SPI Flash EEPROM

Memory

24 DIMM slots with 1DPC that support up to:

6 TB registered ECC DDR5 4800 MT/s speed with AMD EPYCTM 9004 Series processors installed

6 TB registered ECC DDR5 6400 MT/s speed with AMD EPYCTM 9005 Series processors installed

Storage Drives

AS -5126GS-TNRT: Total six drive bays

Two front hot-swap 2.5" SATA drive bays

Four front hot-swap 2.5" NVMe drive bays

AS -5126GS-TNRT2: Total 10 drive bays

Two front hot-swap 2.5" SATA drive bays

Eight front hot-swap 2.5" NVMe drive bays

PCI Expansion Slots

AS -5126GS-TNRT: Up to 10 PCIe 5.0 x16 slots (full-height, full-length) depending on configuration

AS -5126GS-TNRT2: Up to 13 PCIe 5.0 x16 slots (full-height, full-length) + one AIOM/OCP slot

Input/Output

One RJ45 1 GbE dedicated BMC LAN port

Two RJ45 10 GbE BASE-T LAN ports

Two USB 3.2 Gen 1 ports

One VGA port

Motherboard

H14DSG-O-CPU

Chassis

CSE-528G2TS-R000NDP

System Cooling

10 heavy-duty fans with optimal fan speed control

Power Supply

Six 2700 W redundant (3+3) Titanium Level (96%) power supplies. Full redundancy based on configuration and application load.

Input 2700 W: 200-240 Vac

2700 W: 200-240 Vac / 50-60 Hz

2700 W: 240-240 Vdc / 50-60 Hz (for CQC only)

+12 V Max: 225 A / Min: 0 A (200 Vac-240 Vac)

Max: 225 A / Min: 0 A (240 Vdc-240 Vdc)

12 VSB Max: 3.5 A / Min: 0 A

Max: 4 A / Min: 0 A

Operating Environment

Operating Temperature: 10° to 35° C (50° to 95° F)

Non-operating Temperature: -40° to 60° C (-40° to 140° F)

Operating Relative Humidity: 8% to 90% (non-condensing)

Non-operating Relative Humidity: 5% to 95% (non-condensing)

Regulatory Compliance

FCC, ICES, CE, VCCI, RCM, UKCA, NRTL, CB

Certified Safety Models

Compliant with UL or CSA: 528G-H27H14, 528G-27.

Applied Directives, Standards

EMC/EMI: 2014/30/EU (EMC Directive)
Electromagnetic Compatibility Regulations 2016
FCC Part 15
ICES-003
VCCI-CISPR 32
AS/NZS CISPR 32
BS/EN55032
BS/EN55035
CISPR 32
CISPR 35
BS/EN 61000-3-2
BS/EN 61000-3-3
BS/EN 61000-4-2
BS/EN 61000-4-3
BS/EN 61000-4-4
BS/EN 61000-4-5
BS/EN 61000-4-6
BS/EN 61000-4-8
BS/EN 61000-4-11
Environment:
2011/65/EU (RoHS Directive)
EC 1907/2006 (REACH)
2012/19/EU (WEEE Directive)
California Proposition 65
Product Safety: 2014/35/EU (LVD Directive)
UL/CSA 62368-1 (USA and Canada)
Electrical Equipment (Safety) Regulations 2016
IEC/BS/EN 62368-1

Perchlorate Warning

California Best Management Practices Regulations for Perchlorate Materials: This Perchlorate warning applies only to products containing CR (Manganese Dioxide) Lithium coin cells. “Perchlorate Material-special handling may apply. See www.dtsc.ca.gov/hazardouswaste/perchlorate”